



Leica TPS700 Series Field Manual

Version 2.1
English

- when it has to be **right**

Leica
Geosystems

TPS700 - Functions and Programs

Symbols



IMPORTANT NOTICE



To use the equipment in the permitted manner, please refer to the detailed safety instructions in the User Manual.

© 2005 Leica Geosystems AG Heerbrugg, ® All rights reserved.

View of chapters

| | |
|---|------------|
| Point Numbers and Point Search | 7 |
| EDM Settings | 11 |
| Automatic Target Recognition (ATR) | 20 |
| FNC-Key | 24 |
| Start-up programs | 34 |
| Applications | 46 |
| Coding | 108 |
| Menu | 117 |
| Saving Data | 157 |
| Index | 170 |

Contents

| | |
|---|-----------|
| Point Numbers and Point Search | 7 |
| Incrementing point numbers | 7 |
| Individual point numbers | 7 |
| Point Search | 8 |
| Wildcard Search | 10 |
| EDM Settings | 11 |
| Automatic Target Recognition (ATR) | 20 |
| Functionality | 21 |
| ATR-Mode | 22 |
| Automatic Reflector Search | 23 |
| FNC-Key | 24 |
| Change EDM | 25 |
| Point number | 25 |
| Coding | 25 |
| Height Determination of Remote Points | 26 |
| Target Offset | 27 |
| Tracking | 29 |
| Laserpoint | 29 |
| Automatic Target Recognition | 30 |

| | |
|--------------------|----|
| Change in Position | 30 |
| Delete Last Record | 31 |
| Check Tie | 32 |
| REC (Storing) | 33 |
| Distance - Unit | 33 |

| | |
|---------------------------------|-----------|
| Start-up programs | 34 |
| Setting Job | 36 |
| Setting Station | 38 |
| Known Point | 38 |
| Set Manually | 39 |
| Height Transfer | 39 |
| Orientation | 41 |
| Method 1: Set Orientation | 41 |
| Method 2: Measure Target Points | 42 |
| Display of Computed Orientation | 44 |
| Displaying Residuals | 44 |
| Useful Information | 45 |

| | | | |
|-------------------------------------|-----------|--|------------|
| Applications | 46 | Reference Line in regards to the program | 74 |
| Introduction | 46 | Orthogonal Setout | 76 |
| Surveying | 48 | Error Messages | 78 |
| Free Station | 50 | Sets of Angles Measurements | 79 |
| Measuring Facilities | 52 | Introduction | 79 |
| Computation Procedure | 53 | Selecting Sets of Angles functions | 81 |
| Station Setup | 54 | Configuration menu | 82 |
| Measurements | 54 | Define target list | 85 |
| Results | 56 | Sets of measurements | 86 |
| Residuals | 58 | Automatic set measurements | 90 |
| Error Messages | 59 | Calculating the Hz-directions | 93 |
| Setting Out | 61 | Examples and formulas used | 95 |
| Setting Out Coordinates from Memory | 61 | Area Computation | 100 |
| Polar Setout | 63 | Setting-Out via PC | 104 |
| Orthogonal Setout | 63 | | |
| Cartesian Setout | 63 | Coding | 108 |
| Manual Input of Setting Out Values | 64 | Codeblock Searches | 109 |
| Example | 64 | Code List Selection | 111 |
| Error Messages | 65 | Error messages | 113 |
| Tie Distance | 66 | Quick Code | 115 |
| 1. Polygonal Methods (A-B, B-C) | 67 | | |
| 2. Radial Methods (A-B, A-C) | 69 | Menu | 117 |
| Error messages | 70 | Data Manager | 119 |
| Reference Line | 71 | View/ edit Data | 120 |
| Definition of the Base Line | 72 | Delete Memory | 125 |
| Reference Line | 73 | Memory Info | 126 |

| | | | |
|---|------------|--|------------|
| Data Download | 127 | Applications | 159 |
| Messages and Warnings | 129 | Survey Application | 159 |
| Quick Settings | 131 | Setting-Out Application | 160 |
| All Settings | 132 | Tie Distance Application | 160 |
| System Settings | 132 | Area Application | 161 |
| Beep | 133 | Free Station Application | 161 |
| Angle Settings | 137 | Reference Line Application | 163 |
| Units | 141 | Sets of Angles Application | 164 |
| Communication | 142 | Functions | 167 |
| Date and Time | 143 | Determination of the Height of Remote Points | 167 |
| Determining Instrument Errors | 144 | Target Offset | 167 |
| Line-Of-Sight Error (Hz-Collimation) | 146 | Correction Parameters | 168 |
| V-Index (Vertical Index Error) | 146 | EDM | 168 |
| Determining The Line-Of-Sight Error (c) | 147 | Atmospheric Corrections | 168 |
| Determining V-Index | 148 | Coding | 168 |
| ATR collimation | 150 | OSW-Coding | 168 |
| Possible Messages when Determining | | GSI-Coding | 169 |
| Instrument Errors | 153 | Fixed Points (Coordinates) | 169 |
| System-Info | 155 | RS232 | 169 |
| <hr/> | | <hr/> | |
| Saving Data | 157 | Index | 170 |
| Start-Up Programs | 158 | | |
| Job | 158 | | |
| Station | 158 | | |
| Orientation | 158 | | |
| Measuring Application | 159 | | |

Point Numbers and Point Search

Incrementing point numbers

Point number is defined as the current point number in all measuring dialogues. The number at the end of the current point number is incremented by 1. The +1 incrementation step is fixed. If at the end of the point number there is no incrementation, then a number is added after it has been automatically saved.

Examples:

| | |
|-----------------------|-------|
| Current pointnumber : | 12A |
| After saving : | 12A1 |
| Current pointnumber : | A999 |
| After saving : | A1000 |



Letters from A to Z and special characters are not incremented.

Individual point numbers

In the Measurement & Registering menus and in the point recording menu, it is possible to switch between the current and individual point numbers. (see FNC menu, "Insert").

Point Search

The point search is a global function used by applications to search for internally stored measuring points or coordinates. It is possible for the user to limit the point search to a particular job or to search the whole memory.

Job:

PROJ_EAST



Fixed points are always displayed first matching the relevant search criteria. If several points meet the search conditions then the points are arranged depending on "age".

Direct search

By entering an actual point number (e.g. "P13") all points with the corresponding point number are found.

Example:

Input: "P13"

As an example, 2 fixed points and 3 measurements are found. You can page through the match selection using  .

| | | | |
|--------------|----------|------|--|
| FIND POINT < | | 2/5> | |
| Job : | PROJ_OST | | |
| PtID : | P13 | | |
| Type : | FIXPOINT | | |
| E : | 128.400 | m | |
| N : | 244.000 | m | |
| H : | 2.500 | m | |
| <EXIT> | <FINDPT> | <OK> | |

Definition

Fixpoint



The point found is a fixed point.

Measurement

The point found is a measured point.

2/5

The point found is point number 2 of a total of 5 points in this relevant job.

  Scroll within all points matched.

<FINDPT>

Re-enter the search criteria.

 If no suitable point can be found the user is notified by the error message "Point not found".

Point search is always started with the last recorded point. The last entered/measured points are displayed first; fixed points before measured points.

▶ Scroll through the list of points found.

Found:

- ▶ P13, fixed point, time: 9:34:55
- ▶ P13, measurement, time: 14:59:01
- ▶ P13, measurement, time: 15:46:12
- ▶ P13, measurement, time: 16:18:38
- ▶ P13, fixed point, time: 9:52:10
- ▶ to start of list !

👉 At the end of the measured points the search returns to the beginning of the fixed points.

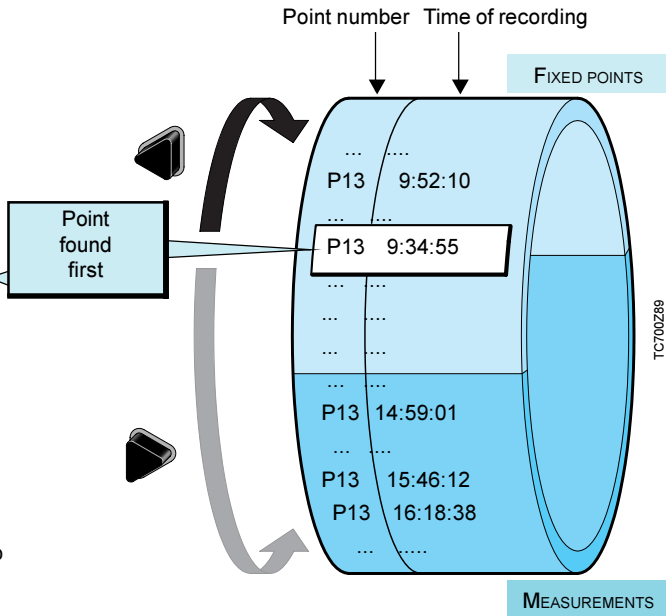

Wildcard Search

The Wildcard search is indicated by a "*". The asterisk is a placeholder for any following sequence of characters.

Wildcards are always used if the point number is not fully known, or if a batch of points is to be searched for.

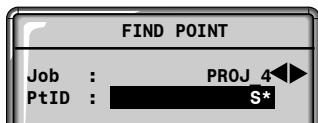

Starts point search.

Examples:

- * all points of any length are found.
- A all points with exactly the point number "A" are found.
- A* all points of any length starting with "A" are found (e.g.: A9, A15, ABCD).
- *1 all points of any length with a "1" at the second place are found (e.g.: A1, B12, A1C)B12, A1C).
- A*1 all points of any length with an "A" at the first place and a "1" at the third place are found (e.g.: AB1, AA100, AS15).

Definition

Fixpoint

The point found is a fixed point.

Measurement

The point found is a measured point.

2/5

The point found is point number 2 of a total of 5 points in this relevant job.



Scroll within all points matched.

<FINDPT>

Re-enter the search criteria.

EDM Settings

The EDM settings contain a detailed menu with selection fields for required settings.

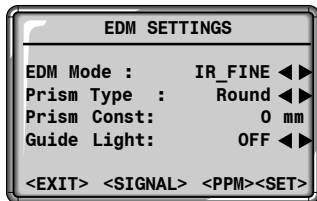

Dist Mode

With TCR instruments, different settings for measurements with visible (RL) laser (optional) for extended range and invisible (IR) EDM types are available. Depending on selected measuring mode the selected prism types are different.



With the RL-EDM each object in the beam is measured (possibly branches, cars, etc.).



Wrong settings by the user (e.g. wrong selection of target type or EDM-type setting) can yield unusable results.



WARNING:

Reflector-free:

The visible laser beam may only be used within a controlled area (*refer to "UserManual", chapter "Safety Directions"*) and must hit a non reflecting material at the end of its intended path.

Long Range to prisms:

This mode is only permissible from a distance of 1000m (3300ft) from the telescope. No persons may stay within the beam path up to 1000m (=controlled area; *refer to "UserManual", chapter "Safety Directions"*).

| Red laser mode | |
|-----------------------|---|
| RL-Short | Short range. For reflectorless distance measurements without prisms |
| RL-Track | Short range. Continuous distance measurement without prisms (< 1 km) |
| RL-Prism | Long range. For distance measurements with prisms from 1 km |

| Infrared mode | |
|----------------------|---|
| IR-Fine | Fine measuring mode for high precision measurements with prisms |
| IR-Fast | Quick measuring mode with higher measuring speed and reduced accuracy |
| IR-Track | Continuous distance measurement |
| IR-Tape | Distance measurement using Retro targets |

Prism type

Open the function in the EDM settings.

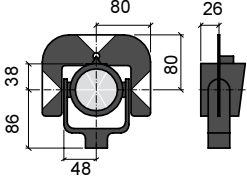
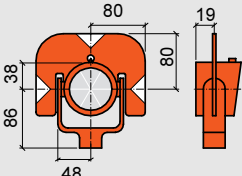
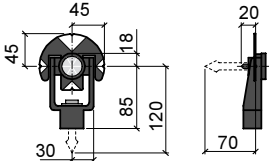
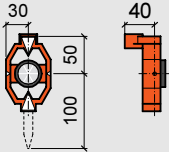
| Leica Geosystems Prisms (Professional Series) | Constants [mm] | Leica Geosystems Prisms (Basic Series) |
|--|---------------------------------------|---|
|  <p>Standard prism GPR121</p> | <p>0.0</p> |  <p>Standard prism GPR111</p> |
|  <p>Mini prism GMP101*/GMP102*</p> | <p>+17.5* 0.0**</p> |  <p>Mini prism GMP111*/GMP111-0**</p> |

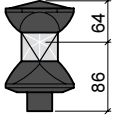
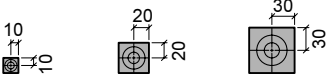
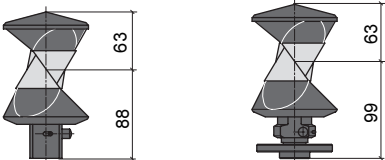
| Leica Geosystems Prisms | Constants [mm] | |
|-------------------------|-------------------|---|
| 360° Prism GRZ4 | +23.1 |  |
| Reflective targets | +34.4 |  |
| 360° Prism GRZ121 | +23.1 | <div style="display: flex; justify-content: space-around;"> <div data-bbox="797 653 1010 684">before 06/2001</div> <div data-bbox="1122 653 1311 684">after 07/2002</div> </div>  |

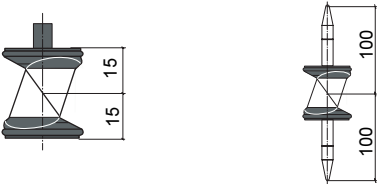
| Leica Geosystems Prisms | Constants [mm] | |
|---------------------------|-------------------|--|
| 360° Mini prism GRZ101 | +30.0 |  |
| USER | - | is set at "Prismconst" (Example next page) |
| RL | +34.4 | Reflectorless |

Prism constant

Open the function in the EDM settings.

Entry of a user specific prism constant. Input can only be made in [mm].

Formula:

Prism constant to be entered
= -mm + 34.4

Example:

Non-Leica Geosystems prism
constant = 14 mm

=>Prism constant to be entered
= -14 + 34.4 = **20.4**

Limit value: -999 mm to +999 mm

Guide Light EGL

The optionally available Guide Light EGL consists of two coloured flashing lights in the telescope of the total station. All TC(R)702/703/705(auto)-instruments can be equipped with this Guide Light. The person at the prism can be guided by the flashing lights directly to the line of sight. The light points are visible up to a distance of 150 meters. This is useful when setting out points.

Off

The automatic Guide Light EGL is switched off.

On

The automatic Guide Light EGL is switched on.



Menu options are only active when an EGL is installed.

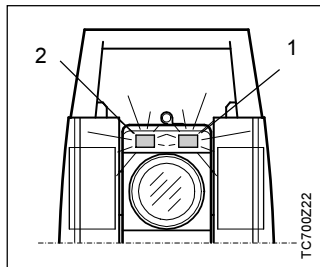

- 1 Flashing red diode
- 2 Flashing yellow diode

Operating range:
5 - 150 m (15 - 500 ft)

Divergence:
12 m (40ft) at 100m (330 ft)

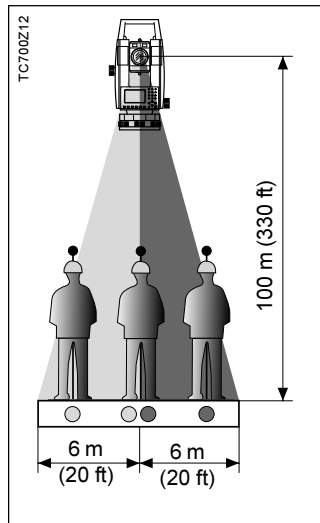

Atmospheric Parameters

Distance measurement is influenced directly by the atmospheric conditions of the air through which distance measurements are taken.

| ATMOSPHERIC PPM | | 1/2 |
|----------------------------|------|-----|
| Temperature : | 12 | °C |
| Pressure : | 1013 | pa |
| Atmos.ppm : | 0 | |
| <EXIT> <SCALE> <P=0> <SET> | | |

| | | |
|--------------|------|---|
| Ht.a.MSL : | 0 | m |
| Refr. Coeff: | 0.13 | |

Under these circumstances, measurements are corrected with atmospheric correction parameters (PPM)

The atmospheric distance corrections are derived from the air temperature, from the air pressure or the height at mean sea level and the relative air humidity or the humidity temperature.

- Pressure
Air pressure at instrument location.
- Ht. a. MSL
Height above sea level at instrument location.
- Temperature
Air temperature at instrument location.
- Rel. Humid.
Relative humidity of air in % (normally 60%)
- Refr.Coeff
Input of refraction coefficient for the atmospheric conditions.
- Atmos_ppm
Calculated and indicated atmospheric ppm.

Refraction correction

The refraction correction is taken into account in the calculation of the height differences and the horizontal distance.

Standard <PPM=0>



Set all values such that the total PPM is equal to "0" (see also "PPM Tables" in section "Atmospheric Corrections").

Scale of projection

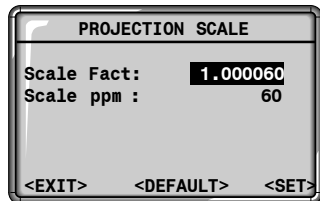

Scale Fact

Entering the scale of projection. Measured values and coordinates are corrected with the PPM parameter.

<DEFAULT>

Sets default parameters.

<SIGNL> button

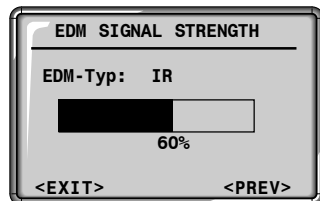

EDM Type:

Indication of current EDM selection (infrared or reflectorless).



Indication of EDM signal strength (reflection strength) in 1% steps. Enables optimum distance measurement to poorly visible targets.

<PREV>

Back to EDM settings.

Automatic Target Recognition (ATR)

TCA and TCRA instruments are motorized and equipped with Automatic Target Recognition (ATR) coaxially in the telescope. The guide light (EGL), mounted on the telescope, is optional. These instruments permit automatic angle and distance measurements to normal prisms and reduce the tedium of precise visual sighting to prisms.

The prism is sighted with the optical sight only. Initiating a distance measurement will turn the instrument with the help of the motors to sight the prism-centre automatically. The angles V and H_z are measured to the centre of the prism completion of the distance measurement.



As with all other instrument errors, the collimation error of the automatic target recognition (ATR) must be redetermined periodically (*Refer to chapter "Checking and Adjusting"*).



Reflected light or light from an outside source (e.g. head lights of a car) can influence ATR measurements.

Functionality

The built-in Automatic Target Recognition ATR transmits a laser beam. The reflected light is received by the built-in camera (CCD). The position of the received light spot with respect to the centre of the CCD is computed and the offsets are used to correct the horizontal and vertical angles. The offsets are also used to control the motors which turn the instrument so that the crosshairs are centred on the prism.

In order to minimize the times for measuring, the crosshair is not moved to the exact centre of the prism. The offset can be up to 5mm. Then the Automatic Target Recognition ATR measures the offsets between the crosshair and prism centre and corrects the Hz and V angles accordingly.

Therefore the Hz and V angles are measured to the prism-centre, regardless of the crosshair pointing precisely to the centre of the prism.

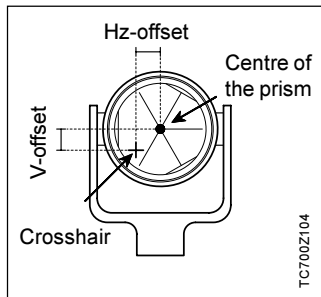

If the offset is more than 5mm when the prism is exactly aligned and in faultless condition, the Automatic Target Recognition ATR must be recalibrated. If excessive offsets occur frequently, contact your Leica Geosystems agency.



The following functions are valid only for TCA and TCRA instruments.

ATR-Mode



This mode permits the automatic recognition of stationary targets.

The observer must first use the optical sight to target the prism approximately so that it is located within the telescopic field of view.

When the distance measurement is triggered, the motors move the crosshair close to the centre of the prism to make distance measurement possible.

Automatic Reflector Search

If the reflector is in the telescope's field of view, the crosshair is automatically positioned to the reflector when a measurement is triggered. If the target is not within the telescope's field of view, an automatic reflector search is started

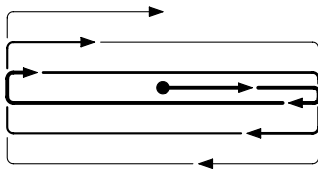

The shape of the search window is rectangular and the defined area is scanned line by line starting in the center of the searching window.



ATR-search procedure can be stopped at any time with the CE key.



Repeated presses on the <RETRY> key triggers a search procedure with ever widening field of view.

FNC-Key



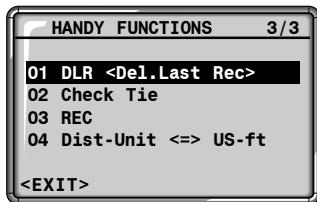
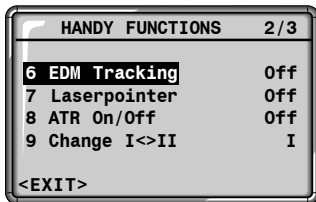
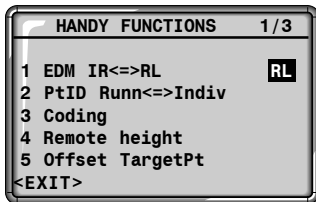

With "FNC" ( + ) different functions are available.



 Application of individual functions are described in this section.

Functions can also be started directly from the different applications.

Each function from the FNC menu can be assigned to the  key (see section "Menu/Settings").

 Each function can be started either using the shortcut with the corresponding data entry key or selected with  /  and the selection confirmed with . In this User Manual only the shortcut method of starting the functions is given.

 The first 9 functions can be called up as usual with the numerical 1,2,.. keys. The following functions can be called up with a valid two digit number beginning with zero (e.g. 01).

Change EDM

- 1 Direct call up of the "Change EDM" function.

Change between the two EDM modes: IR (Infra red) and RL (Reflectorless). The new setting is displayed for about one second and is then activated.

IR: Infra red: invisible distance measurement using reflectors.

RL: Visible laser: distance measurement without reflector for up to max. 300m, with reflector from 1000m onwards.

More information is available in section "EDM-Settings".

Point number

- 2 Direct call up of the "PtID. Run<=>Indiv" function.

Change between individual and running point numbers.

Coding

- 3 Direct call up of the "Coding" function.

Select code from the OSW-codelist or enter a new code.

| CODE/ATTR. ENTRY | | 1 / 3 |
|------------------|----------------|-------|
| Code : | Proj. distance | |
| Attr1 : | | 0st |
| Attr2 : | | ----- |
| <EXIT> | | <REC> |

Height Determination of Remote Points

- 4 Shortcut to the function "REMOTE HEIGHT (REM)".

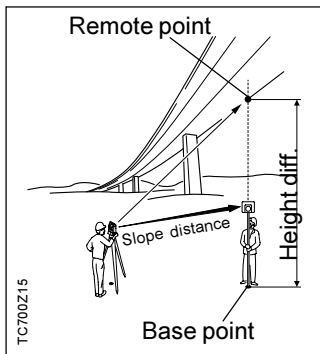

Points directly above the base prism can be determined without a prism at the target point.

Measure base point:

1. Enter point number and prism height.

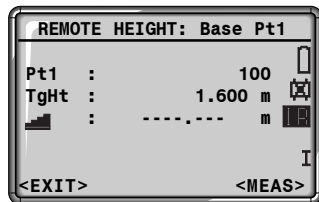

2. Trigger distance measurement and indication of horizontal distance () with **<MEAS>**.

<MEAS>

Measure and record the base point.

Determine remote point:

3. Aim at the remote point with the telescope .

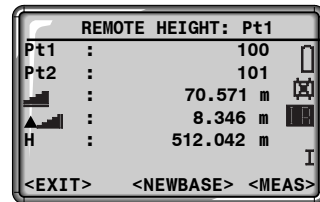

4. Store with <MEAS> measured data of the remote point. No new distance measurement is carried out.

Height (H) and height difference (▲) as function of actual V-angle and measured distance to base point are computed and displayed immediately.

<NEWBASE>

Enter and measure a new base point.

Target Offset

5. Shortcut to the function "OFFSET".

If it is not possible to set up the reflector directly, or it is not possible to aim the target point directly, the offset values (length, cross and/or height offset) can be entered. The values for the angle and distances are calculated directly for the target point.

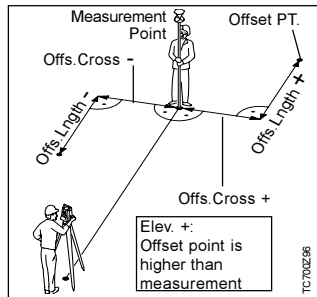

| OFFSET TARGET-PT. | |
|-------------------|-------------------|
| LOffs: | 2.200 m |
| TOffs: | 3.660 m |
| HOffs: | 1.780 m |
| Mode : | Reset after REC◀▶ |
| <EXIT> | <RESET> <SET> |

Procedure:

1. Enter the point ID and the reflector height
2. Enter the offset values (length, cross and/or height) as per the sketch
3. Define the period for which the offset is to apply.
4. <SET> calculates the corrected values and jumps to the application from which the offset function was started. The corrected angle and distances are displayed as soon as a valid distance measurement has been triggered or exists.

<EXIT>

Leaves the function and returns to the application from which the function was started.

The period of applicability can be set as follows:

| | |
|------------------------|--|
| Reset after REC | The offset values are reset to 0 after the point is saved. |
| Permanent | The offset values are applied to all further measurements. |



The offset values are always reset to 0 when the application is quit.

Tracking

 Shortcut to the function "TRACKING".

Switches on or off the tracking measurement mode. The new setting is displayed for approx. one second and then set. The function can only be activated from within the same EDM type and prism type.

The following options are available:

| EDM Type | Tracking measurement mode Off <=> On |
|-----------------|---|
| IR | IR-Fine <=> IR_Track / IR-Fast <=> IR-Track |
| RL | RL-Short <=> RL-Track |

The last active measurement mode remains set when the instrument is switched off.

Laserpoint

 Shortcut to the function "LASERPOINTER".

Switches on or off the visible laser beam for illuminating the target point. The new setting is displayed for approx. one second and then set.

Automatic Target Recognition

-  Directly calling up the function "ATR On/Off"

Directly switches ATR mode on/off. ATR (ON/OFF) is displayed for one second and then carried out. Switching the ATR function on (ATR ON), automatically places the instrument in EDM measurement mode (IR-fine). This EDM mode remains selected even after ATR function has been turned off (ATR OFF) . If after switching off the ATR a different EDM mode is needed, (e.g. RL-short), then it has to set from the EDM menu.

Change in Position

-  Directly calling up the function "Changing position I<>II". (only for motorized instruments).

When this function is called up the instrument performs a change in position. The motors turn the instruments and the target in the new position is visible in the telescopic viewer. This function is specially useful in conditions of poor visibility.



Pressing  can stop a change in position at any time.

Delete Last Record

 Shortcut to the function "DLR <DEL.LAST REC>".

This function deletes the last recorded data block. This can be either a measurement block or a code block.



Deleting the last record is not reversible !



Only records can be deleted which were recorded in "Surveying" or in "Measuring".

Not permitted to delete last record

- Current setting for data storage is "RS232" (see section "Configuration"). Measured data has been output via interface and so cannot be deleted in the field memory.
- Record cannot be deleted because last data set was not registered either in "Surveying" nor in "MEASURING".
- The last record has been already deleted. Function cannot be activated any more.





Check Tie

- 0 2 Shortcut to the function "CHECK TIE".

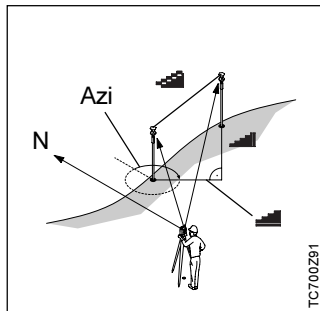
Calculation and display of the slope and horizontal distance, height difference, azimuth, and co-ordinate differences between the last two measured points. Valid distance measurements are required for the calculation

(, ).



| CHECK TIE | |
|---|-------------|
| Brg : | 85° 19' 35" |
|  : | 9.011 m |
|  : | 9.059 m |
|  ΔE : | 8.768 m |
|  ΔN : | 2.077 m |
|  : | 0.939 m |
| <EXIT> | |

Important Messages

Less than 2 valid measurements!

Meaning

The values cannot be calculated as there exist less than 2 valid measurements.

REC (Storing)

- 0 3 Actual measured data is stored by "REC" to the internal memory or via the serial interface.

By activating "REC" the following actions are carried out:

- Recording a measurement block.
- Incrementing of current point number.



Distance - Unit

- 0 4 Direct call up of the "Dist-unit <=> US-ft" function.

From the current unit measures (e.g. meters) "US feet"- units are switched to and vise-versa.

Start-up programs

Start-up programs are a set of functions for successful stations setup and data management. The user can select start-up programs individually.

 Opens the program menu, execute an application with .

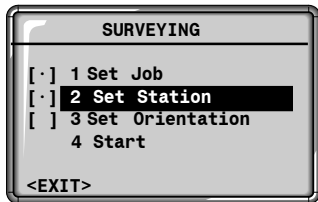

A "*" indicates that a job is set and that in the job set the last station/ orientation in the memory correspond to the actual station/ orientation.

 Shortcut to a start-up program by pressing the corresponding data entry key

or

 Select or skip a start-up program. The selection is marked by the black bar.



Execute the marked start-up program.

<EXIT>

End start programs and returns to Measurement & Registration.



The individual start programs are described in detail on the following pages!

Error messages:

"SET A JOB FIRST"

"NO JOB IN SYSTEM"

- No valid job set.
- > Carry out "SET JOB" and select a valid job or generate a new one.

"SET A STATION FIRST"

"NO STATION IN SYSTEM"

- No valid station defined in the job.
- > Carry out "SET STATION" and define a valid station. Note that a job was already set.

"SET ORIENTATION FIRST"

"NO ORIENTATION IN SYSTEM"

- No orientation set in the job.
- > Carry out "SET ORIENTATION" and make sure that JOB and STATION are valid.

Setting Job

All data is saved in JOBS, like directories. Jobs contain measurement data of different types (e.g. measurements, codes, fixed points, stations,...) and are individually manageable and can be readout, edited or deleted separately.

If a job was not yet defined and **ALL** or REC is activated in "MEASURE" the system automatically generates a job with name "DEFAULT".
Using the SurveyOffice software package TPS300/700 Tools "TPS setup" the number of available jobs can be either set to 8 (mixed data management: Measurements

and fixed points) or to 16 (only measurements or only fixed points).

Remarks

1/2 Job no 1 of a total of two available jobs.

Selection

Using the arrow keys you can scroll within the available jobs. Select the desired job.

<NEW>

Defines a new job. Activates a display for input of a new job name and user.

<SET>

Sets job and returns to start-up program overview.

<EXIT>

Back to startup program overview.



All subsequent recorded data is stored in this job/ directory.



Date and time are automatically placed by the system and cannot be changed.

Setting Station

Each coordinate computation relates to the currently set station. Therefore, at least station point plan coordinates (E_0 , N_0) are required. The station height can be entered optionally. The coordinates can be entered either manually or read from the internal memory.

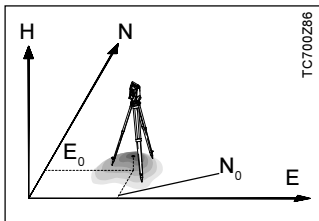

Known Point

| SET STATION | |
|-------------|--------------|
| Stn: | P12 |
| InHt : | 1.600 m |
| E0 : | 1000.000 m |
| N0 : | 1000.000 m |
| H0 : | 1000.000 m |
| <H-TRANS> | <BACK> <SET> |

1. Enter a point number from the memory.
2. **<SET>**
Sets and records station coordinates. Return to start-up program overview.

3. Wildcard search (place focus on PtNr., enter Wildcard "*" with **SHIFT** **±**) start the global search for any point in saved in the memory.

<H0-TRANS>

Starts the "HEIGHT TRANSFER" function.

Set Manually

If an entered point number cannot be found in the internal memory then the manual input is activated automatically.

1. Enter Point ID.
2. Enter co-ordinates and height.
3. **<OK>** : Sets and records station co-ordinates. Return to "SET STATION".

Height Transfer

The height transfer function defines the height of the position of the instrument from measurements to a target point of known height.

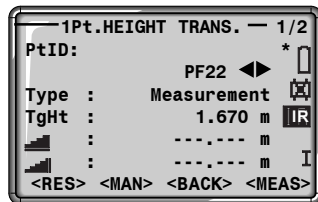
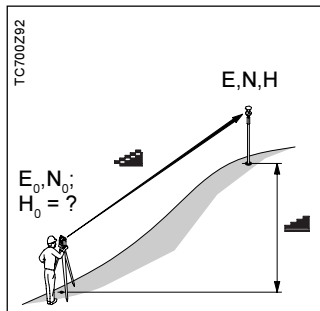





Expands the display.

<MAN>

Opens manual height entry.

Procedure:

1. **<H0-TRANS>** in the "SET STATION" display starts the height transfer and carries out a point search using the wildcard criterion (*), i.e. the last point measured/entered is displayed first, fixed points before measurements.
2. Enter the required point number for the target point or page through the list of points found using  .
3.  /  / **<MEAS>**: Measurement to the selected target point.
4. **<RES>**: Display of the results.

| HEIGHT TRANSFER RESULTS | | |
|-------------------------|-----------|-------|
| Stn : | | STN1 |
| PtID : | | PF22 |
| H0 I : | 436.719 m | |
| H0 II : | 435.065 m | |
| Mean : | 435.892 m | |
| <END> | <NEW> | <SET> |

The following are displayed:

- Station name
- Point ID of the target point
- Calculated station height (H0) from measurement in the corresponding telescope face. If measurements are performed in both telescope face, the measurements are averaged.



If the calculated H0 values deviate between the first and second telescope face by more than 10 cm from another, an error message is displayed. The message should be checked. H0_middle is calculated in any case.

<OK>

Back to the SET STATION display, H0 is set and only saved with <SET>.

<NEW>

Starts a new measurement

<EXIT>

Ends the height transfer, returns to SET STATION display (H0 is not set).

Orientation

This program enables an orientation angle to be entered manually, or for the orientation to be determined by measurement to points with known co-ordinates. Orientation co-ordinates can be either obtained from the internal memory or entered manually. Using button <Hz0> the orientation can be set to 0.000 quickly and easily.

The system offers the following possibilities:

- Set any Hz-value manually.
- With <Hz0> set Hz=0.000.
- Orientation to target points with known co-ordinates.

Method 1: Set Orientation

Set any Hz-orientation

By entering the Hz-angle the user can set any Hz-orientation.

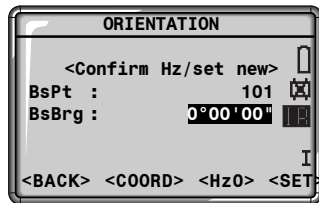

 Moves cursor to input field "BsBrg".

 Enters new angle.

 Deletes field or sets to 0°00'00\".

 Confirm parameters

Set Hz0

With the <Hz0> display key the Hz direction can quickly and easily be set to 0°00'00\".

<Hz0>

Set Hz-orientation to 0°00'00\".



If the ATR is on and the Hz direction is set to $0^{\circ}00'00''$, then deviations could appear due to the ATR's position e.g. $0^{\circ}00'05''$ to the Design value of $0^{\circ}00'00''$. The instrument is functioning correctly.

<OK>

Confirms the orientation if no entry has been made, or sets and records the new orientation if a new point ID has been entered, or a new Hz-angle has been set.

Method 2: Measure Target Points

For determining the orientation, a maximum of 5 target points with known coordinates can be used.

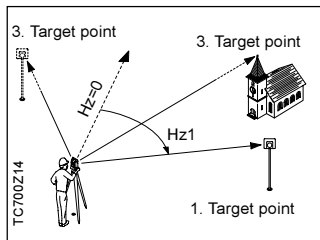

Orientation co-ordinates can be either obtained from the internal memory or entered manually.

If an orientation point number cannot be found in the internal memory then the instrument automatically activates the manual entry of the co-ordinates.

<COORD>

Activates input/edit mode for entry of a known orientation point.



Dialog for orientation to several target points.

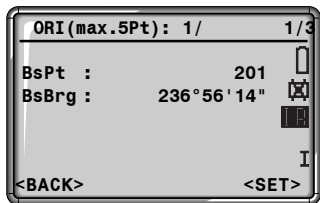

▲Hz:
 After the first measurement the finding of other target points (or the same point when changing the telescope position) is easier by setting the indicated angle difference near to 0°00'00" by turning the instrument.

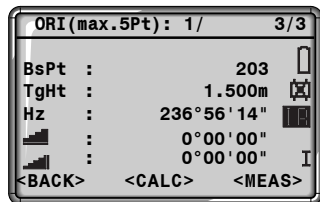
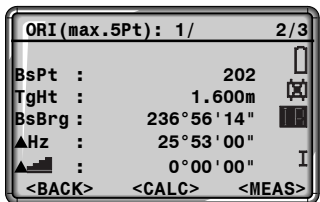

▲: Difference between horizontal distance to target point computed from coordinates and the measured distance.

MEAS

An angle and a distance measurement is triggered. If no distance can be measured only an angle measurement is made.

1/I Status indication; shows that first point was measured in telescope face I.

1/I II First point measured in telescope face I and II.



Motorized instruments align themselves directly to the next orientation point.

Display of Computed Orientation

<SET>

Displays orientation results if several target points are measured.

| ORIENTATION RESULT | |
|--|------------|
| NoPts : | 2 |
| Stn : | 200 |
| HzCor : | 123°00'23" |
| StDev : | ± 0°00'08" |
| <p><END> <RESID> <SET></p> | |

<SET>



Sets computed Hz-orientation.

If more than one target point is measured then the orientation is computed using the "least squares method".

Displaying Residuals

<RESID>

Displays residuals.

| ORI . RESIDUALS | |
|---|----------|
| BsPt : 2/2 | |
| BsPt : | 2 |
| ▲ Hz : | 0°00'23" |
| ▲  : | ----- m |
| ▲  : | ----- m |
| <p><END> <BACK> <SET></p> | |

▲ : Height residuals

▲ : Correction on the horizontal distance

▲ Hz: Correction on Hz-angle.

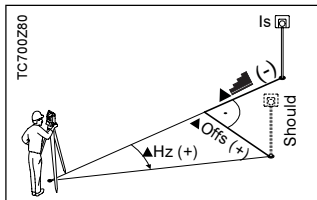

Useful Information

- If the orientation is **only** measured in telescope face II the Hz-orientation is based on telescope face II. If measured **only** in telescope face I or mixed the Hz-orientation is based on telescope face I.
- The prism height may **not** be changed during measurements in the first and second telescope face.
- If a target point is measured several times in the same telescope face the **last valid** measurement is used for the computation.

Applications



Depending on local software versions the contents of the displays (lines) described in this section can differ. However, the function of the relevant display remains the same.



Before starting an application, make sure the instrument is perfectly levelled up and the station data is correctly set.

Button functions



Triggers a distance measurement.



Measures **and** records the measured values.



When starting an application the dialog with the Start-up programs is called automatically (see section "*Start-Up Programs*").

Introduction

With these onboard applications the functionality of the TC(R)702/703/705(auto) instruments is improved considerably.

As a result, the functionality is extended and the daily surveying fieldwork is made easier. By using internally recorded values the user is mainly protected from entering incorrect data. Points with given coordinates as well as measured points can be used within the programs.

The following programs are available in the internal memory:

- Surveying
- Setting Out
- Tie Distance
- Area
- Free Station
- Reference Line
- Sets of angles



With TC(R) auto instruments, automatic target recognition feature is available for all applications (ATR).



Opens the program menus.

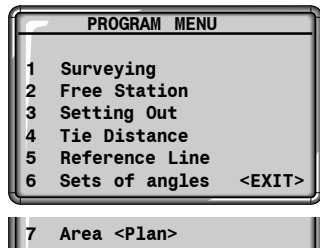

Start the required application directly by pressing the corresponding data entry key.

or



Selects the desired application.



Opens the application and activates the Start-up programs.

Surveying

With the program "Surveying" the measuring of an unlimited number of points is supported. The program can be compared to simple measuring. Only the guided stationing or orientation (see "Start-Up Programs") and the additional display for target coordinates are different.

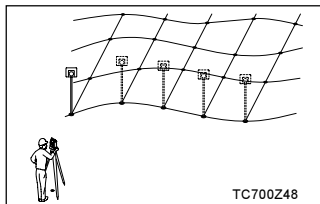

Measured data can either be recorded in the internal memory or output via serial interface RS232 (see "Configuration / Interface Parameter").

Procedure:

1. Input of point number.
2. Input of code, if required (see also "CODING")
3. Enter new reflector height or change the existing height.
4. Trigger and record measurements with **ALL**, **DIST** or **USER** (if REC is assigned).

<QCODE>

Start the "Quick Code" function



Find further information about coding or about quick code in section "CODING".

With **SHIFT**, **▲** / **▼** you can switch quickly and easily between different displays.

Measuring display 1

```
----- SURVEYING ----- 1/3
PtID  :          AB-12
TgHt  :          1.600 m
Hz    :    123°12'34"
V     :    79°56'45"
      :    412.883 m
<EXIT>          <QCODE>
```

Measuring display 2

```
----- SURVEYING ----- 2/3
PtID  :          AB-12
TgHt  :          1.500m
Code  :          -----
Hz    :    123°12'34"
      :    406.542 m
      :    72.081 m
<EXIT>          <QCODE>
```

Measuring display 3

```
----- SURVEYING ----- 3/3
PtID  :          AB-12
TgHt  :          1.500m
Code  :          -----
E     :    1739.420 m
N     :    932.711 m
H     :    456.123 m
<EXIT>          <QCODE>
```

Free Station

The application "Free Station" is used to determine the instrument position from measurements to a minimum of two known points and a maximum of five known points. It supports measurements to points using either distances and Hz- and V-angles (typical 2 point resection) or angles only (typical 3 point resection) or a combination of angles and distances to different points. Only for TC(R) auto instruments.



After the instrument has calculated the current station from the measured points, the telescope is automatically positioned on every following target point. Just make sure the point number is entered and the point was found in memory or that after entering it manually, the **<OK>** button is pressed.

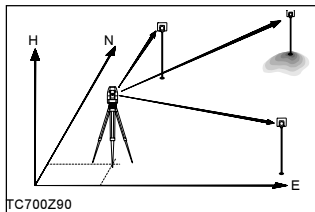

The following measurements sequences to target points are possible:

1. Hz- and V-angles only.
2. Distance and Hz- and V-angle.
3. Hz- and V-angles to some point(s) and Hz- and V-angle plus distance to other point(s).

The final computed results are Easting, Northing and Height of the present instrument station, including the instruments Hz-circle orientation. Standard deviations and residuals for accuracy assessments are provided additionally.

Measurements and results (position, standard deviations and residuals) are always recorded to the internal memory, provided the internal memory is set as the Data Storage media.



All displays shown are examples. Local software versions may differ from the basic version.

Measuring Facilities

The points can be measured in telescope face I or II, or a mixture (I + II), the sequence is of no significance. E.g. first point in telescope face II, last point in telescope face I + II, second point in face I, etc.



Measurements made in both telescope faces are checked for gross errors to ensure that the same point has been aimed at.

If a target point is measured several times in the same telescope face the **last valid measurement** is used for computation.

Measurement restrictions:

- **2 face measurements**

For measurements in 2 faces, the reflector height and the refraction coefficient **must** be kept the same for both faces for the same target point, although it is permissible to change these parameters between different target points. An error message will be generated if the reflector height changes between face I and face II while measuring to the same target point.

- **Target points with 0.000 height**



Target points with 0.000 height are discarded for height processing. If target points have a valid height of 0.000 m, use 0.001 m to enable it for height processing.

Computation Procedure

The computation procedure automatically defines the calculation method, e.g. 2 point resection, 3 point resection with angles only, etc...).

If more than the minimum required measurements are performed, the processing routine uses a least squares adjustment to determine the plan position and averages orientation and heights.

1. The original averaged face I and face II measurements enter the computation process. In case of multiple measurements to the same target point, only the last measurement for each face enter the computation process.

2. All measurements are treated with the same accuracy, whether these are measured in single or dual face.

3. The final plan position (E, N) is computed from a least squares adjustment, including standard deviations and residuals for Hz-angle and horizontal distances.

4. The height of the station (H) including the standard deviation and residual is calculated from the averaged heights (based on the original measurements).

5. The Hz-circle orientation is computed with the original averaged face I and face II measurements and the final computed plan position.

Station Setup

Set the occupied station name and instrument.

Procedure:

1. Enter the station name (Stn)
2. Enter the instrument height (hi):

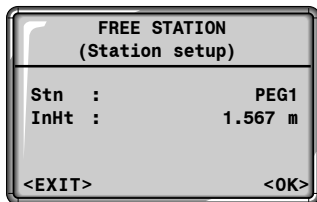

<OK>

Proceeds to the measurement screen.

<EXIT>

Back to start-up program

Measurements

Free Station methods:

- **2 point resection**
=> **always** use the **ALL**-key or the Button <MEAS>
- **3 point resection with angles only**
=> Always use the REC-command under the FNC-menu or the **USER**-key if REC is assigned to it.
- **Mix of distances and angles**
=> Use either **ALL**-key or the Button <MEAS> for distances and angles or REC-command for angles only.

Procedure:

1. Enter the target point number (PtID).
If the desired point is not found within the internal memory, the system automatically opens the manual coordinate entry.
2. Enter the reflector height (hr).

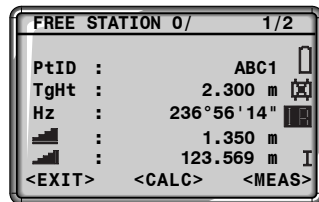

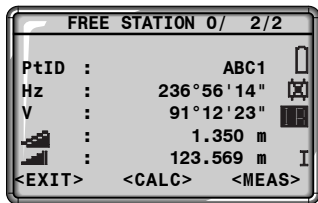

<MEAS>

Button initiates measurements.

- a) If the target is a prism, the angles (Hz and V) and distance are automatically measured and recorded.
- b) If the target is not a prism or the reflectorless EDM cannot measure a distance, only Hz- and V-angles are measured and recorded.

c) If no target is found with the ATR activated, an error message is displayed.

REC

Measures and records Hz- and V-angles.



Measuring and registering Hz-direction, V-angle and H0 distance .

<CALC>

Computes and displays the instrument position if at least 2 points in single face with at least one distance are measured.

<EXIT>

Back to the start-up program overview.

1/I Status indication; shows that first point was measured in telescope face I.

1/I II Shows that first point was measured in telescope face I and II.

Results

This dialog shows the final computed station co-ordinates and instrument height.

| FREE STATION RESULT | 1/2 |
|---------------------|---------------|
| Stn: PEG1 | |
| E0 : 14757687.345 m | |
| N0 : 16934025.602 m | |
| H0 : 1243.932 m | |
| InHt : 1.576 m | |
| <EXIT> | <RESID> <SET> |

1st page (display of station co-ordinates and instrument height)

Stn = Name of occupied station

E0 = Computed station Easting

N0 = Computed station Northing

H0 = Computed station Height

hi = Instrument height

<SET>

Sets the displayed co-ordinates and instrument height as a new station.

<RESID>

Displays the residuals.



<EXIT>

Quits the application "FREE STATION" without setting the new station data to the system.



If the instrument height was set to 0.000 in the setup screen, then the station height refers to height of trunnion axis.

2nd page:

  Displays standard deviations

| FREE STATION RESULT 2/2 | | |
|-------------------------|---------|-----------|
| #Pts | : | 3 |
| s.Dev E | : | 0.012 m |
| s.Dev N | : | 0.120 m |
| s.Dev H | : | 0.035 m |
| s.DevAng | : | +0°00'23" |
| <EXIT> | <RESID> | <SET> |

Pts = Number of measured points

s.Dev E = Standard deviation Station Easting

s.Dev N = Standard deviation Station Northing

s.Dev H = Standard deviation Station Height

s.DevAng= Standard deviation circle orientation

SET>

Sets the displayed coordinates and instrument height as a new station.

<RESID>

Displays the residuals.

<EXIT>

Quits the application "FREE STATION" without setting the new station data to the system.

Residuals

This dialog shows the computed residuals.

The residuals always show computed value (given data) minus measured value.



Use the cursor keys to change between the display of residuals for the various measured points.

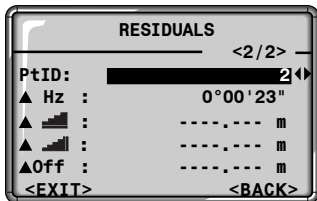

<BACK>

Returns to the result screen.

<EXIT>

Quits the application "FREE STATION" without setting the new station data to the system.



Error Messages



| Messages | Meaning |
|----------------------------------|--|
| Selected point has no valid data | This message occurs if the selected target point has no easting or northing coordinate |
| Max 5 points supported | If already 5 points are measured and a further point is selected . The system supports maximum 5 points |
| Bad data - no position computed | The measurements may not allow to compute final station coordinates (Easting, Northing) |
| Bad data - no height computed | Either the target height are invalid or insufficient measurements are available to compute a final station height. |

| Messages | Meaning |
|--|--|
| Not enough memory! | The present selected job is full and does not allow further storage. This error could occur either with measurements or when the system stores result data, such as station results, standard deviations or residuals. |
| Hz (I - II) >1gon (54') measure point again | This error occurs if a point was measured in one face and the measurement in the other face differs by more than $180^\circ \pm 0.9^\circ$ for the horizontal angle circle |
| Hz (I - II) >1gon (54') measure point again | This error occurs if a point was measured in one face and the measurement in the other face differs by more than $180^\circ \pm 0.9^\circ$ for the vertical angle reading |
| More points or distance required | There are insufficient data measured to be able to compute a position. Either there are not enough points used or not enough distances measured. |

Setting Out

The application computes setting-out elements for the **polar**, **cartesian** or **orthogonal** setting out of points using either co-ordinates or manually entered angle, horizontal distance and height. Setting out differences can be displayed continuously. In the Setting out program three different displays are available showing setting out values corresponding to the relevant method.

  Switches the display and method.

A point search with the wildcard criterion (*) is automatically performed on starting setting-out, i.e. the last point measured/entered is displayed first, fixed points before measurements. Points can be easily selected by scrolling through with  / .

Additionally, the type of the point found (fixed point or measured point) is displayed.

Setting Out Coordinates from Memory

Input a point number.
If the desired point number could not be found the system opens the manual coordinate entry automatically.

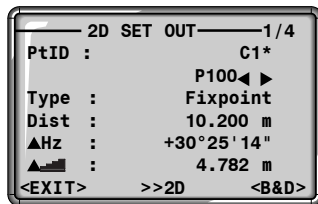













<B&D>







Switches the instrument to "Manual input of setting out values".

  Changes to 3D set out.

 Motorized instruments automatically turn the telescope to the set out point. For >>2D only Hz, for >>3D Hz and V.

| 3D SET OUT | | 2/4 |
|-------------------------|------------|---|
| PtID.: | C1* |  |
| | P100◀▶ |  |
| TgHt : | 1.500 m |  |
| ▲Hz : | +30°25'14" |  |
| ▲ : | 4.782 m |  |
| ▲ : | 3.528 m |  |
| <EXIT> >>2D >>3D <VIEW> | | |

| 3D SET OUT | | 3/4 |
|-------------------------|---------|---|
| PtID : | C1* |  |
| | P100◀▶ |  |
| TgHT : | 1.500 m |  |
| In/Out: | 2.805 m |  |
| Left/R: | 4.782 m |  |
| ▲ : | 0.428 m |  |
| <EXIT> >>2D >>3D <VIEW> | | |

| 3D SET OUT | | 4/4 |
|-------------------------|---------|---|
| PtID : | C1* |  |
| | P100◀▶ |  |
| TgHt : | 1.500 m |  |
| ▲E : | 3.505 m |  |
| ▲N : | 2.482 m |  |
| ▲ : | 1.228 m |  |
| <EXIT> >>2D >>3D <VIEW> | | |

Polar Setout

Normal indication of polar setout offsets ΔHz , \blacktriangle , $\blacktriangle H$.

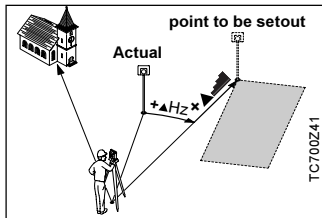

- ΔHz : Angle offset: positive if point to be setout is to the right of the actual direction.
- \blacktriangle : Longitudinal offset: positive if point to be setout is further away.
- $\blacktriangle H$: Height offset: positive if point to be setout is higher than measured point.

Orthogonal Setout

The position offset between measured point and setout point is indicated in a longitudinal and transversal element.

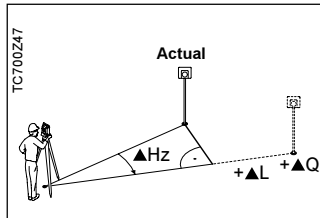

- ΔL : Longitudinal offset: positive if nominal point further away.
- ΔT : Transversal offset, perpendicular to line-of-sight: positive if nominal point is to the right of measured point.

Cartesian Setout

Setting out is based on a coordinate system and the offset is divided into a north and east element.

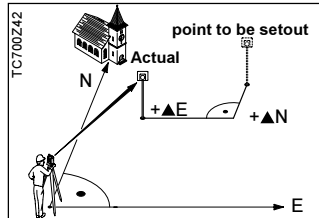

- ΔE Easting offset between setout and actual point.
- ΔN Northing offset between setout and actual point.



Manual Input of Setting Out Values

1. Enter direction (Brg), horizontal distance (Dist) and height (H) of setout point.
4. The setout offsets are displayed in the same way as with the polar setout.

| BEAR & DIST ENTRY | |
|-------------------------|--------------|
| PtID : | ABC1 |
| Brg : | 123° 12' 36" |
| Dist : | 123.569 m |
| H : | 12.456 m |
| <EXIT> <BACK> <SET> | |



<PREV>

Changes to 2D/3D setting out (ref. to section "Setting out coordinates from memory").

2. <SET> : The entered data is set. Calling the setting out dialog.
3. Trigger measurement with  or .

Example

By entering a wildcard (*), a group of points can be found easily and set out one after the other.



| 3D SET OUT <B&D> -2/4 | |
|-------------------------------|--|
| PtID : | C1* |
| TgHt : | P100◀▶ 1.500 m |
| ▲Hz : | +30° 25' 14"  |
| ▲Hz : | 4.782 m |
| ▲Hz : | 3.528 m  |
| <EXIT> >>2D >>3D <VIEW> | |

Procedure:

1. Enter "C1*" in the "PtID" field.

2.  starts the point search and finds all points that meet the search criterion (e.g. C10, C11, C12, ...)

| | | |
|--------------|-----------|------|
| FIND POINT < | | 3/6> |
| Job : | Proj_A4 | |
| PtID : | C12 | ◀▶ |
| Type : | Fixpoint | |
| E : | 735.482 m | |
| N : | 633.711 m | |
| H : | 141.581 m | |
| <EXIT> | <FINDPT> | <OK> |

3. Using   you can page quickly through the points found.

<EXIT>

Leaves point search without selecting a point. Back to setting-out.

<FINDPT>

Re-enter the search criteria.

<OK>

Selects the required point and returns to setting-out.

Error Messages

No or invalid Ptid or coords:

- The point number entered is not available.
- > Re-enter point number/co-ordinates.

Invalid entries of data:

- Manually entered setting out data is incomplete (e.g. setting out distance missing).
- > Check setout parameter and re-enter.

Tie Distance

The application **Tie Distance** computes slope distance, horizontal distance, height difference and azimuth of two target points measured **online**, selected from the **Memory** or entered using the **Keypad**.

Distances and directions between two successive points are determined and can be saved in the internal memory (e.g 3 to 4).

The user can choose between two different methods:

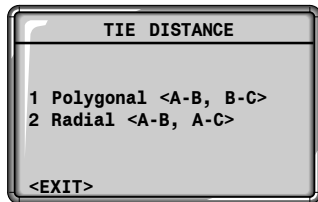

1. Polygonal Methods (A-B, B-C)

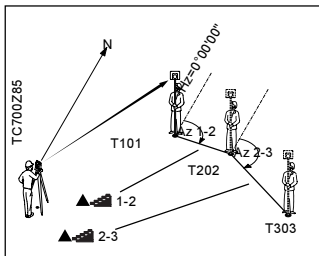

1. Enter desired point number and reflector height for the first target point.

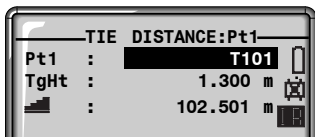

2. Aim on target point and measure.
(**ALL**, **DIST** / REC, <MEAS>)

- 2.1 Variant on 2: instead of measuring the target point, it can also be selected from the memory or entered using the keypad. (<COORD>)

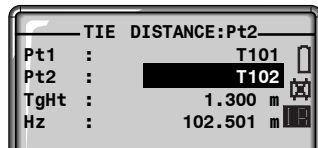

3. Enter desired point number and reflector height for the second target point. The previously measured point number is displayed.





4. Aim on target point and measure.
(**ALL**, **DIST** / REC, <MEAS>)

Results

Finally, the results are displayed.

| TIE DIST <Pt1-Pt2> | | |
|---|---------|-----------|
| Pt1 : | | T101 |
| Pt2 : | | T102 |
| Brg : | | 30°25'14" |
|  : | | 124.145 m |
|  : | | 1.634 m |
|  : | | 2.678 m |
| <EXIT> | <NewP1> | <NextP2> |

-  Horizontal distance between point 1 and point 2.
-  Height difference between point 1 and point 2.

 Slope distance between point1 and point 2.

Azi Azimuth between point 1 and point 2.

<NewPt1>

An additional missing line is computed. Program starts again (at point 1).

<NextPt2>

Point 2 is set as starting point of a new missing line. New point (Pt 2) must be measured.

2. Radial Methods (A-B, A-C)

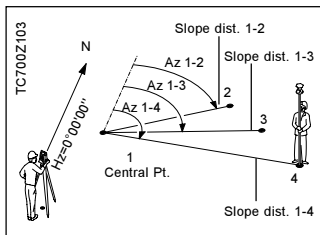

1. Enter desired point number and reflector height for the first target point.

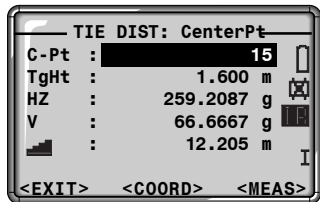

2. Aim on target point and measure.
(**ALL**, **DIST**) / REC, <MEAS>
- 2.1 Variant on 2: instead of measuring the target point, it can also be selected from the memory or entered using the keypad. (<COORD>)
3. Enter desired point number and reflector height for the second target point. The previously measured point number is displayed.

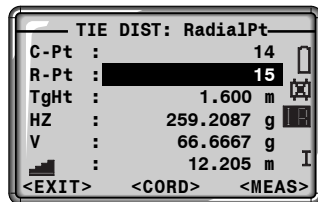

4. Aim on target point and measure. (**ALL**, **DIST**) / REC, <MEAS>

Results

Finally, the results are displayed.

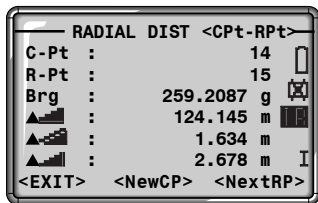

<NewCP>

Measure new centre point. Program starts again (at point 1).

<NextRP>

Measure new radial point (centre point Pt. 1 is retained)

Error messages

"No Distance measured"

- Distance measurement has not been carried out or not saved.

> Make the measurement again.

Reference Line

This program facilitates the easy setting out or checking of lines for buildings, straight sections of road, simple excavations, etc. A reference line can be defined with reference to a known base line, which, e.g. has been defined based on an existing site boundary. The reference line can be along or set parallel to the base line and rotated around the base point as desired.

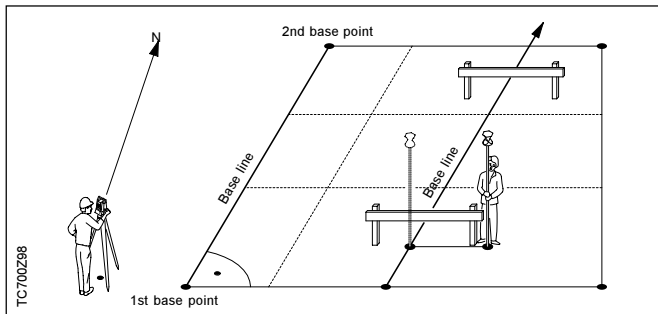



Definition of the Base Line

The base line is given by two base points. The base points can be defined in three ways:

- Measure point
- Enter co-ordinates using keypad
- Select point from memory.

Definition of the base points:

a) Measuring base points:

Input a point number and independent measurement of the base points using , or / REC.

- b) Base points with co-ordinates:
Input a point number. The search for associated points in the memory can be initiated using <COORD>.

If the required point is not in memory or there are no valid co-ordinates in the memory, the program prompts for manual entry of the co-ordinates.

Analogue procedure for the second base point.

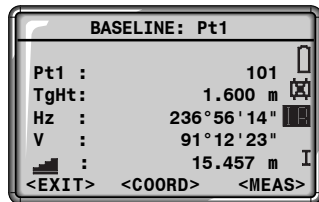

<EXIT>

Return to the start-up programs.

<COORD>

Activates selective point search (see "Point Search" section)

<FINDPT>

Activates selective point search (see section of same name)

<OK>

Confirms the entry and continues the program.

<NewL>

New entry of the first base point.

 Triggers a distance measurement.



 Triggers a distance measurement and register the measured data.

Reference Line

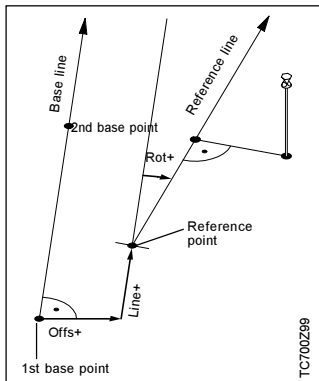
The base line can be offset longitudinally and in parallel, as well as rotated. This new line is called the reference line. All measured data refers to the reference line.



Input of the parameters:

Using the navigation keys  , the focus can be moved to the offset and rotation parameters for the reference line.

| BASE.LINE SHIFTS | |
|---------------------------|-----------|
| Pt1 : | 101 |
| Pt2 : | 102 |
| Rot. : | 1.000 m |
| Offs : | 5.450 m |
| Line : | 20°00'00" |
| HOffs : | 0.000 m |
| <EXIT> <NewL><L&0> <RefL> | |

The following entries are possible:

- Offs+:** Parallel offset of the reference line to the right, referred to the direction of the base line (1-2).
- Line+:** Longitudinal offset of the start point (=reference point) of the reference line in the direction of base point 2.
- Rot+:** Rotation of the reference line clockwise around the reference point.
- Hoff+:** Height offset; the reference line is higher than the first base point.

Reference Line in regards to the program



The calculation of the reference line is performed in stages as per the diagram shown on the left.

<EXIT>

Return to the start-up programs

<NewL>

Return to the definition of a new base line.

<L&O>



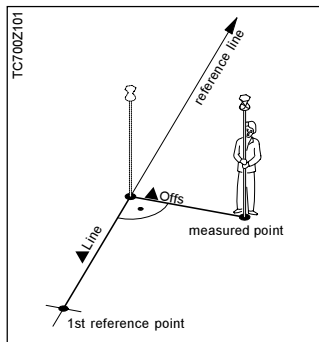

Opens the "Orthogonal Setout" application.

<RefL>

Opens the "Reference Line" application



The <RefL> function calculates longitudinal, transverse and height differences relative to the reference line. After the first distance measurement, the measurement dialog displays the calculated values (▲Line, ▲Offs, ▲) continually if tracking mode is activated.

| REF. LINE MEASURE | |
|---|--|
| PtID : | 103 |
| TgHt : | 1.550 m  |
| ▲Offs: | -0.054 m  |
| ▲Line: | 0.020 m |
| ▲  : | 0.120 m  |
| <EXIT> | <SHIFTS> |

DIST Triggers a distance measurement.

ALL Measures and registers measured data.

<EXIT>

Return to the start-up programs

<RefL>

Redefine reference line.

The height of the first reference point is always used as the reference height for the calculation of height differences (▲▲▲▲).



If tracking mode is activated (see "EDM Settings section"), correction values for the position of the reflector are displayed continuously.

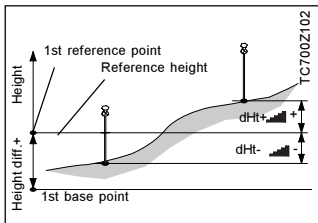

Orthogonal Setout

Relative to the reference line you can enter longitudinal, transverse and height offsets for the target points to be set-out. The program then calculates the differences between the measured point and the calculated point. The program displays either the orthogonal (\blacktriangle Line, \blacktriangle Offs, \blacktriangle Line) or the polar differences (\blacktriangle Hz, \blacktriangle Line, \blacktriangle Line). By "making" these differences as small as possible, you can position the prism on the point to be set-out.



Motorized instruments align automatically with the set-out point.

Using SHIFT \blacktriangle / \blacktriangle , you can switch between polar and orthogonal setting out differences.



If tracking mode is activated (see "EDM Settings" section), correction values for the position of the reflector are displayed continuously.

Example "orthogonal methods"

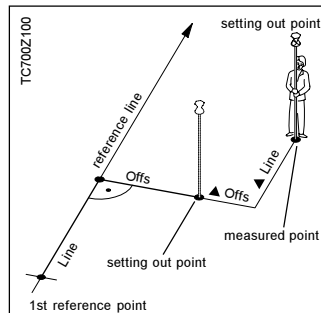

Offset input:

| INPUT LINE&OFFSET | |
|-------------------------|----------|
| PtID : | 103 |
| TgHt : | 1.550 m |
| Offs : | 3.750 m |
| Line : | 10.500 m |
| HOffs : | 1.500 m |
| <EXIT> <SHIFTS> <STAKE> | |

Display in measure mode:

| STAKE LINE&OFFS | | 1/2 |
|---------------------------|-------------|-----|
| PtID : | 103 | |
| TgHt : | 1.550 m | |
| ▲Hz : | -0° 15' 20" | |
| ▲ | 1.220 m | |
| ▲ | 0.350 m | I |
| <EXIT> >>2D <SHIFT> <L&O> | | |

| | | |
|---------|----------|--|
| ▲Offs : | 3.750 m | |
| ▲Line : | 10.500 m | |
| ▲ | 0.350 m | |

<EXIT>

Return to the start-up programs.

<SHIFTS>

Redefine reference line.

<SAKE>

Set-out points.

<L&O>

Input new setting out elements.

Triggers a distance measurement.

Triggers a distance measurement and register the measured data..

The signs for the distance and angle differences are exactly the same as for the "Setout" application. These are correction values (required minus actual).

+▲Hz Turn telescope clockwise to the setting out point.

+▲ The setting out point is further away than the point measured.

+▲ The setting out point is higher than the measured point.

Error Messages

| Messages | Meaning |
|-----------------------|--|
| Base line too short | Base line is shorter than 1 cm. Choose base points such that the horizontal separation of both points is at least 1 cm. |
| Distance not measured | No distance measured or invalid. Repeat distance measurement until a valid distance is displayed. |
| Coordinates invalid | No co-ordinates or invalid co-ordinates for a point. Ensure that a point used has at least one Easting and one Northing co-ordinate. |

Sets of Angles Measurements

Introduction

This optional set of angles application is protected by a license code.

It is used to determine angles to target points of which the coordinates do not have to be known. As an option their distances can be measured, too. This program includes methods of testing and analyzing measurements.

In this way, measurement data can be tested for accuracy before leaving the current setup.

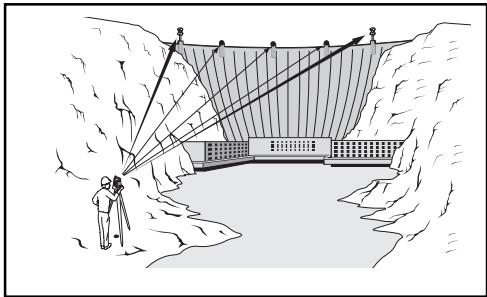

With motorized instruments (TC(R)700auto) target points can be aimed at automatically requiring only fine aiming. This prevents the selection of wrong target points.

On TC(R)700auto instruments fine aiming can be automated using ATR (Automatic Target Recognition), if the targets have reflectors placed on them.

Only the first measurement to each target point has to be made, the rest of the measurements are performed automatically by the program.

At least two complete sets of measurements in face I and face II must be made for the required calculations. The sets of angles program saves the position of each target point, the corresponding EDM-mode, the reflector height, the type of prism, the additive constant and the ATR-status.

All this data is used to complete all the further measurements carried out by the program.

The maximum amount of measurements that can be made and saved depend on the memory capacity of the instrument. However only the first 64 measurements made in two faces are used for the calculations. For example 16 sets of 4 target points or 8 sets of 8 target points, etc.



The storage capacity of the instrument's memory space is limited to about 8000 measurements.

Selecting Sets of Angles functions

The **Sets of Angles** application is designed to enable programs 1 to 6 to be processed in sequence from the top down.

When one of the programs has been processed, a [•] appears at the front, with the exception of the configuration program.

Before starting the program "Define Targets" we recommend that the parameters for the "Configuration" are defined first.

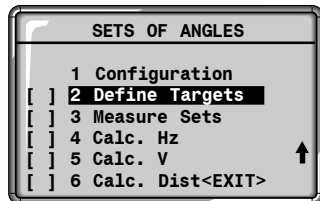

<EXIT>

Exits the program.

Configuration menu

In this program parameters like measurement tolerances and measurement methods are defined. These definitions are valid for all target points measured.

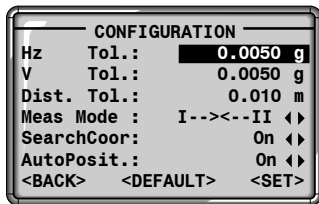

<BACK>

Moves back to program selection without saving any data.

<DEFAULT>

Loads standard configuration.

<SET >

Loads user defined parameters to the program.

<Shift CE>

Jumps back to function selection without saving any data.

Hz Tol.:

Enter a tolerance parameter for the Hz-direction. It is the limit for the deviation of the measured parameters from the directions measured in the first half set.

V Tol.:

Enter a tolerance parameter for the vertical angle. It is the limit for the difference of the current angle to the angle measured in the first half set.

Dist. Tol.:

Enter a tolerance parameter for distance measurement. It is a limit for the difference between the currently measured distance and the one measured in the first half set.



If the set limit is exceeded during a measurement a warning is displayed:

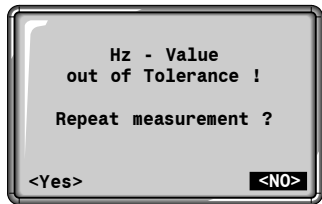

The warning can be answered as desired with <Yes> or <No>.

Meas Mode:

I→←II

Targets measured in the first face are measured with backsight in the second face.

I→II→

All targets are measured in both faces in the same sequence.

I/II→I/II

After measurements in the first face measurements are done in the second face at once.



The selected sequence of sightings should be adhered to while making manual measurements.

SearchCoord:

Only active on TC(R)auto instruments.

On

Searches the coordinates of the point currently in memory. TC(R)auto instruments position themselves automatically on the target. Then only fine aiming is required. If desired, the ATR can perform that task also.

Off

No coordinates are searched for. In this case the instrument can be manually positioned on each measured point. If desired, the ATR in TC(R)auto instruments can perform fine aiming, too.

AutoPosit.

Only active on TC(R)auto instruments.

On

The telescope is automatically moved to the next measured point including changing face if required. The actual measurement can be triggered with <Meas>, DIST +REC or ALL in the measurement display.

Off

There is no automatic alignment and consequently no automatic changing of face. All targets can be targeted manually.



If coordinate search is on in TC(R)auto instruments then auto positioning is also ON as coordinate search only makes sense if automatic positioning follows.



The set configuration remains saved even after exiting the program.

Define target list

In this part of the program the point numbers of the targets and the measuring sequence of the subsequent sets of measurements are defined. A maximum of 24 target points can be defined.

The desired point numbers can be entered manually or read in from measured point or fixed point data in memory.

 The **first** 24 fixed points resp. the **last** (most current) 24 measurements in the memory are read in.

| — DEFINE TARGETLIST — | | 1/4 |
|--------------------------|-------|-----|
| Pt 1: | | 100 |
| Pt 2: | | 101 |
| Pt 3: | | 102 |
| Pt 4: | | 103 |
| Pt 5: | ----- | |
| Pt 6: | ----- | |
| <GetPts> <CLR ALL> <SET> | | |

<GetPts>

Read in fixed points or measurements from data in memory.

<CLR ALL>

The entire list is cleared (deleted) and a new one can be defined.

<Shift CE>

Moves back to program selection without saving any data.

<SET>

Confirm defined list. The point numbers are brought into the correct sequence. Program moves back to program selection.



After calling up the "Sets of measurements" program the target list can no longer be edited.

Sets of measurements

If the point numbers of the target points listed are stored in memory of the instrument then automatic instruments position themselves on the target point.

In the configurations menu the options "AutoPosit." and "SearchCoor" must be set to "On".



We recommend starting the measurements in face 1.

If the defined point numbers are not stored in the instrument's memory or if the defined target points are stored but "SearchCoor" in the configurations menu is "Off", the following message appears:

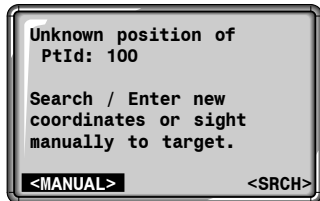

<MANUAL>

Each target can be measured manually. The following is displayed on the measurement screen.

<SRCH>

Starts searching for a target point. If the point is stored in memory it can be selected from the display. If the point is not stored its coordinates can be entered. In both cases the following appears on the measurement display.

The measurement display is set up as follows:

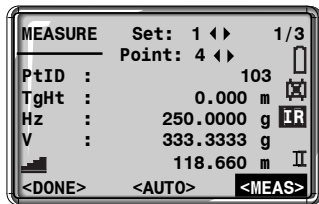

<DONE>

Once the current set of measurements has been completed the display moves back to the program selection menu.

If the current set of measurement are not yet complete the following message is displayed:

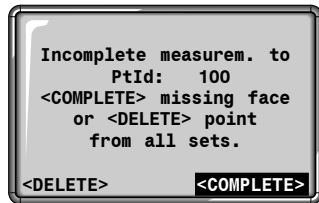

<AUTO>

Is only available after each target has been measured at least once.

<MEAS>

The current target is measured.

The first line displays the current set of measurements. The next line shows the current point to be measured. Point number, position and elements of measurement are also displayed. Reflector height can be entered individually for each point.

The currently displayed point can be measured by pressing <MEAS>, DIST+REC or ALL, after selecting EDM mode, the type of prism, the prism constant and the ATR status.

With automatic instruments ATR can perform fine aiming. For every measured point the instrument saves the current position, the type of prism, the prism constant, the EDM mode, the ATR status and the current reflector height.

In the following second face resp. in the following sets of measurements these parameters are automatically applied to each new target. If the set parameters are changed for a target always the latest (newest) settings are used.



If erroneously a wrong target, a wrong prism constant or a wrong EDM mode is selected the measurement can be repeated.

Select the erroneous point of the set with the arrow keys and repeat the measurement.

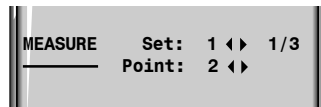

The EDM mode, the type of prism and the prism constant can be selected and set using the short-cut SHIFT+EDM as displayed on page 87.



Switching functions on and off (e.g. ATR) can be done with the short cut SHIFT + FNC (FNC menu is called up).

After completing the first measurement of all defined points in face 1, motorized instruments position themselves automatically on the current point to be measured in face 2 (depending on the settings in the configurations menu).

If in the configuration menu measuring method I/II→I/II was selected, make sure that all points were measured in both faces. Only then will <AUTO> be displayed, meaning that automatic measurement is now possible.



For automatic measurements all target points must have prisms and the ATR must be on.

If ATR is not on at a target, the instrument stops at that target. The point has to be measured manually.

Automatic set measurements

Press <AUTO> for automatic set measurements and the following is displayed:

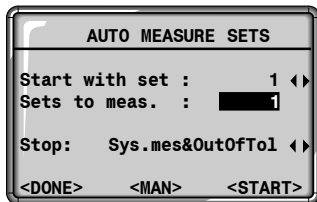

<MAN>

Moves back to the display on page 87. Measurements may be done manually.

<START>

Starts automatic measurements.

<DONE>

is basically active. If the measurement of the defined targets were not completed in both faces a warning is displayed. The incomplete target points can be deleted from all sets or completed in all sets.

Otherwise <DONE> ends all measurements. The next part of the program "Calc. Hz " from the program selection menu may be started.

Start with set

In the first line the set with which the automatic measurement should start is defined. This selection is useful if several sets were already manually measured.

Basically the next set to be measured is displayed. If an already measured set is selected with the arrow keys then after pressing <START> a query is displayed asking if the set is to be deleted and remeasured or if it is possibly an incomplete set and should be completed.

Sets to measure

Enter in this line the amount of sets to be measured automatically.

Stop:

Sys.mes & Out of tol.

Automatic measurement is stopped when the tolerance set in the configuration menu is exceeded or a system message (e.g. from the slope sensor or ATR).

System messages only

Measurement is only stopped by a system message (e.g. from the slope sensor or ATR). Exceeded tolerances are not reported.

<START> displays the automatic measurement.

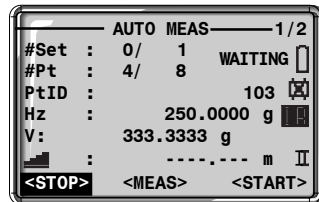

<STOP>

Pressing <STOP> twice completely stops automatic measurement. On acknowledging the message the display moves back to "AUTO MEASURE SETS".

Pressing <STOP> once interrupts automatic measurement, but supplementary manual measurements can still be done by pressing <MEAS>.

<START>

Starts automatic measurement or completes an interrupted one.

The current status is displayed in the first line:

RUNNING

Current measurement is running

WAITS

Automatic measurement is interrupted. Manual measurements can be made or pressing <START> resumes automatic measurement.

Set and point:

The first number shows how many sets resp. targets in the current sets have already been measured. The second number shows the total number of sets resp. target per set. Each point is measured twice (face I and II). Therefore, a total of six measurements are required for three points.

After all automatic measurements have been made the display returns to "AUTO MEASURE SETS". If in the mean time automatic measurement was interrupted by pressing <MEAS> and measurements were done manually, <STOP> has to be pressed again to move back to the display "AUTO MEASURE SETS".

Calculating the Hz-directions

The following display shows the results of the calculated measurements. The display of the results of V-angle and slope distances (points 5 and 6 of the program selection menu) are similar and will not be described in details here.

| RESULT Hz | |
|----------------------|----------|
| Active Sets: | 2 |
| Active Pts : | 4 |
| σ Single Dir: | 0.0000 g |
| σ Avg. Hz : | 0.0000 g |
| <BACK> | <STORE> |
| | <MORE> |

<BACK>

Moves back to program selection without saving any data.

<STORE>

Calculations are done with the number of points and number of sets shown on the display and then stored.

<MORE>

Calculated results are displayed in more detail.

Active sets

Amount of sets used in the calculation.

Active pts

Amount of points used in the calculation.

σ Single dir (Hz)

Standard deviation of a single set of directions resp. of a single V-angle.

σ Avg. (Hz)

Average standard deviation of all sets of direction resp. the average of a single angle from all sets.



Basically all collected elements of measure flow into the calculation if they were not deselected.

Add new calculations with <STORE> to already calculated results.

Should further information be required pressing <MORE> calls up the following display.

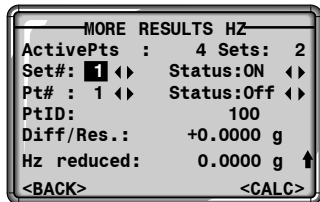

<BACK>

Moves back to the display on page 93 without saving any changes (results of Hz-set of measurements).

<CALC>

Recalculates standard deviation after deactivating certain single points or sets.

Active Pts

Amount of active points used in the calculation.

Sets

Amount of active set used in the calculation

Set# /Status

Use set for the calculation [ON/ OFF].

Pt#/Status

Use target point for calculation [ON/OFF].

Pt.ID.

Target point number.

Diff / Res

Difference of the sets of directions (resp. distance) and the averaged directions (resp. distance) from all sets.

Hz-reduced

Reduced set average resp. averaged V-angle.



Rendering sets inactive, renders the points they contain inactive too.

Examples and formulas used

The example of a Hz-measurement is shown in the following table:

The example shows a measurement in 3 sets and 4 target points with direction indication in 360° ' " .

The calculations in the program are according to the following table.

Calculation of Hz-Sets of Angles:

| Pt.no. | Face I | Face II | Average of faces I-II (a) | Reduced set average (b) | Averaging (d) | r= d - b | v= r+q | v ² |
|--------|------------|------------|---------------------------|-------------------------|-------------------|--------------------|---------------|----------------|
| 1 | 0°00'20" | 180°00'17" | 0°00'19" | 0°00'00" | 0°00'00" | 0 | +1 | 1 |
| 2 | 24°43'34" | 204°43'31" | 24°43'33" | 24°43'14" | 24°43'10" | -4 | -3 | 9 |
| 3 | 84°47'15" | 264°47'11" | 84°47'13" | 84°46'54" | 84°46'53" | -1 | 0 | 0 |
| 4 | 306°41'52" | 126°41'42" | 306°41'47" | 306°41'28" | 306°41'28" | 0 | +1 | 1 |
| | | | | | $q = -(\sum r)/N$ | $q = \frac{-5}{4}$ | $\sum v = -1$ | |
| 1 | 45°00'13" | 225°00'16" | 45°00'15" | 0°00'00" | | 0 | 0 | 0 |
| 2 | 69°43'24" | 249°43'23" | 69°43'24" | 24°43'09" | | +1 | +1 | 1 |
| 3 | 129°47'06" | 249°47'08" | 129°47'07" | 84°46'52" | | +1 | +1 | 1 |
| 4 | 351°41'45" | 171°41'44" | 351°41'45" | 306°41'30" | | -2 | -2 | 4 |
| | | | | | $q = -(\sum r)/N$ | $q = \frac{-0}{4}$ | $\sum v = 0$ | |
| 1 | 90°00'19" | 270°00'19" | 90°00'19" | 0°00'00" | | 0 | -1 | 1 |
| 2 | 114°43'28" | 294°43'26" | 114°43'27" | 24°43'08" | | +2 | +1 | 1 |
| 3 | 174°47'10" | 354°47'15" | 174°47'13" | 84°46'54" | | -1 | -2 | 4 |
| 4 | 36°41'47" | 216°41'45" | 36°41'46" | 306°41'27" | | +1 | 0 | 0 |
| | | | | | $q = -(\sum r)/N$ | $q = \frac{-2}{4}$ | $\sum v = -2$ | |
| | | | | | | | $\sum v^2 =$ | 23 |

Average error of a direction measured in both faces, averaged and reduced hz-direction.

$$\sigma_{mR} \text{ (Hz)} = \sqrt{\frac{\sum v^2}{(N-1)(s-1)}} = \sqrt{\frac{23''}{(4-1)(3-1)}} = \pm 2''$$

Average error of a direction averaged from all sets.

$$\sigma_{mM} \text{ (Hz)} = \frac{\sigma_{mR} \text{ (Hz)}}{\sqrt{s}} = \frac{2''}{\sqrt{3}} = \pm 1''$$

The example of a V-measurement is shown in the following table:

The example shows a measurement in 3 sets and 4 target points with direction indicated in 360° ' ' ' ' .

The calculations in the program are done according to the following table.

Calculation of V-Sets of Angles:

| Pt. no. | Face I | Face II | Average face I+II (a) | Averaging (d) | v = d-a | v ² |
|---------|-----------|------------|-----------------------|---------------|--------------------|----------------|
| 1 | 87°13'58" | 272°46'24" | 87°13'47" | 87°13'46" | -1 | 1 |
| 2 | 88°42'12" | 271°18'18" | 88°41'57" | 88°41'55" | -2 | 4 |
| 3 | 89°44'22" | 270°16'00" | 89°44'11" | 89°44'11" | 0 | 0 |
| 4 | 91°06'47" | 268°53'38" | 91°06'34" | 91°06'33" | -1 | 1 |
| | | | | | | |
| 1 | 87°14'01" | 272°46'22" | 87°14'49" | | -3 | 9 |
| 2 | 88°42'09" | 271°18'20" | 88°41'54" | | +1 | 1 |
| 3 | 89°44'27" | 270°16'00" | 89°44'13" | | -2 | 4 |
| 4 | 91°06'47" | 268°53'40" | 91°06'33" | | 0 | 0 |
| | | | | | | |
| 1 | 87°14'01" | 272°46'34" | 87°13'43" | | +3 | 9 |
| 2 | 88°42'09" | 271°18'20" | 88°41'54" | | +1 | 1 |
| 3 | 89°44'23" | 270°16'04" | 89°44'09" | | +2 | 4 |
| 4 | 91°06'49" | 268°53'42" | 91°06'33" | | 0 | 0 |
| | | | | | Σ V= -2 | |
| | | | | | Σ v ² = | 34 |

Average error of a V-angle measured in both faces.

$$\sigma \text{ mR (V)} = \sqrt{\frac{\sum V^2}{N * 1 s - 1}} = \sqrt{\frac{34''}{4 * 3 - 1}} = \pm 2''$$

Average error of a V-angle averaged from all sets.

$$\sigma \text{ mM(V)} = \frac{\sigma \text{ mR (V)}}{\sqrt{s}} = \frac{2''}{\sqrt{3}} = \pm 1''$$

If only one target with several sets were measured, then the standard deviation is calculated as follows:

$$\sigma \text{ mR (Hz/V)} = \sqrt{\frac{\sum V^2}{s - 1}}$$

The average error, $\sigma \text{ mM (Hz/V)}$ is calculated as already shown above.

a = A direction averaged and measured in both faces.

b = A reduced direction averaged in both faces of a set.

d = Final direction averaged from all sets.

r = Difference between final and reduced set direction for Hz-directions

q = Arithmetic average of the differences (r).

v = Improvements in the directions

s = Number of sets

N = Number of target points

r = d - b

v = r + q for Hz direction.

v = d - a for V- direction.

Distance calculations:

The calculations are done analogue to the "V-Sets of Angles".

Area Computation

The application areas (plane) computes online areas from an unlimited number of points connected by straight lines.

From three measured points the area is computed and displayed on-line. By activating <RESULT> the number of points used, the computed area and the closed polygonal length (e.g. line 1-2-3-4-1) are saved and displayed.



The points can be measured optionally in the first or second telescope face. Between the individual points the telescope face can be changed. One distance must always be measured.

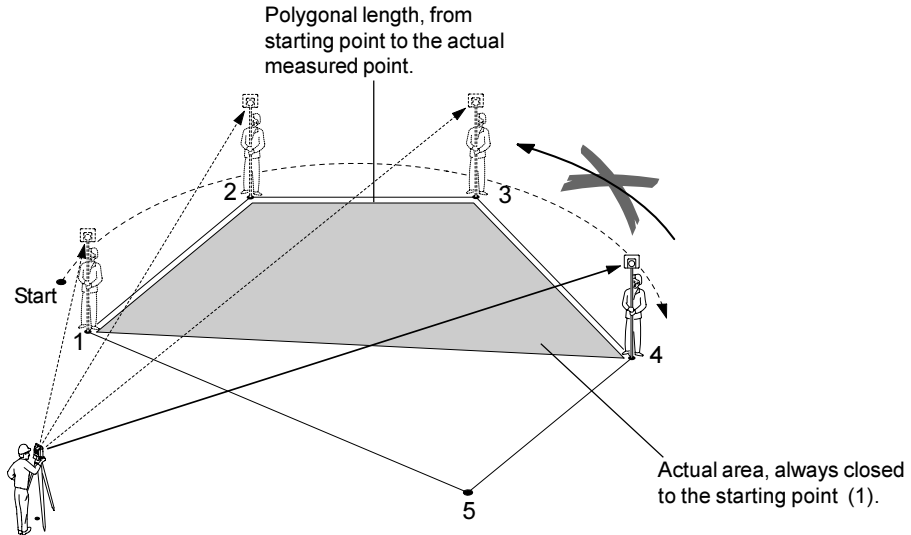

1. Input of point number.
2. Trigger a distance measurement: This can be achieved in the following ways:

<MEAS>

Triggers and records a measurement. Point counter and point number are incremented.

 Same function as <MEAS>.

 Triggers and displays a distance measurement.

REC

Save with REC if key  is assigned accordingly.

<RES>

Records areas, perimeter and point counter.

Measuring display

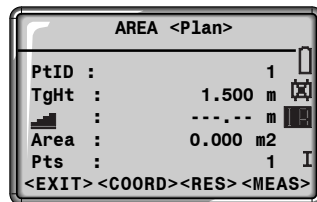

 The area is always displayed according to the onboard unit setting (m², hectare).

Results

| AREA <Plan> | | RESULT |
|-------------|---------|----------------|
| NoPts : | | 15 |
| Area : | 148.472 | m ² |
| Area : | 0.014 | ha |
| Perim: | 65.241 | m |
| <EXIT> | | <NEW> |

Displayed are:

- area
- number of measured points
- circumference of closed area/
length of closed polygon.

<NEW>

Starts a new area computation.
The counter is set to "0" again.

<EXIT>

Quits the program area
computation.

Setting-Out via PC

When Setting-out via PC is used, data is sent from a computer (field computer, external data recording unit) to the instrument. In general, this data is either coordinates or calculated data, e.g. angles or distances.

Following transmission of the necessary data, the corresponding screen is displayed, i.e. either setting-out with co-ordinates or setting-out with azimuth, distance and height. The subsequent procedure for setting-out points is the same as in the "Setting-Out" application on the instrument.

Procedure**RS232-Command**

1. Open the start dialog.



setout CRLF

c CRLF

2. Transferring set-out point parameters or set-out point coordinates.

Data Type**RS232 Command**

Point ID (PtID):

PUT/11....+12345678_CRLF

Bearing (Brg):

PUT/24...2+12345678_CRLF

Horizontal distance (Dist):

PUT/34...0+12345678_CRLF

Easting coordinate (E):

PUT/81...0+12345678_CRLF

Northing coordinate (N):

PUT/82...0+12345678_CRLF

Height (H):

PUT/83...0+12345678_CRLF

(_ = space)

Once the required data has been transferred to the instrument, the display changes automatically and shows the difference in the direction to the point to be setout.

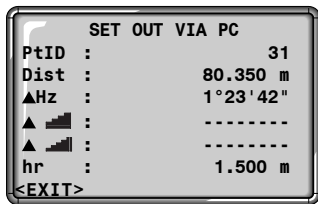

DIST Following the distance measurement, the horizontal distance difference and the height difference to the point to be setout are displayed.



or REC transmission of the measured data to the external data recording unit. Measurements including data recording can also be triggered from the external data recording unit.



The measured data is always transmitted over the RS232 interface and is never written to the internal memory in the instrument.

Further commands

| | RS232-Command |
|--------------------------|---------------|
| Inputs new data | c CRLF |
| Quits setting-out via PC | x CRLF |

Further displays



Change to further displays with additional data in accordance with the selected setting-out method:

- Setting out with azimuth, distance, and height; change to orthogonal setting out (dL, dQ, dH) and display of the setting out values (\blacktriangle L, Q, \blacktriangle H) and the station data (E0, N0, H0, hi).
- Setting out with coordinates: change to orthogonal (\blacktriangle L, \blacktriangle Q, \blacktriangle H) or cartesian setting -out (\blacktriangle E, \blacktriangle N, \blacktriangle H) and display of the setting-out values (PtID, E, N, H, Brg, Dist).

Coding

Any desired information can be saved in codes. Normally point information is saved. Several blocks of codes can be saved between measurements.

Code structure

Code : Code name

Rem. : Additional remarks

Attrib. : User defined attribute name while creating the code list. ,
As default Info 1:...Info 8: is used.

Val. : Value of attribute that can be entered or edited when the code is called up.

GSI code lists created with TCTools or in T100-Instruments can still be used.

Preparing a code list

With the computer program "Codelist-Manager", included in the "Leica Survey Office" program code lists with up to , 200 codes with descriptions, attributes etc. can be prepared easily and quickly, meaning that e.g. instead of Info1/Attrib1, "Pkt-Art" may be defined. The defined text is then display on the instrument's screen when the appropriate attribute value is entered.

The program enables the assignment of so called quick code numbers to the individual codes.

The completed code list can then be loaded into the "Data Exchange Manager" (also included in the "Leica Survey Office" program) of the instrument.

Codeblock Searches

Basically there are two ways of entering codes and attributes into the list or selecting them from the list.

1. Directly in the measurement display "Measuring & Registering" or in the "Surveying" application. These codes are point referenced and are not saved right after they were entered or selected but only together with the next measured point data. (ALL or REC-fixed key). The codeblock contains the same point number as the measurement.

If the code is to be saved before or after the measurement can be set in the system configuration.

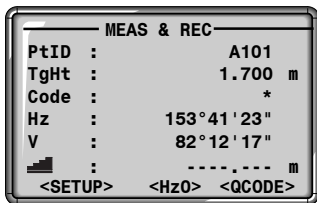

1.1 Place cursor on "Code" .

1.2 Enter wildcard joker (e.g. T*) or exact code discription and confirm with . Code function is activated.

2. Using the FNC menu.

These codes are saved as independent code blocks. It is possible to sequentially save several code blocks. This type of coding is always available and can be called up in every application.

In both of the described ways the entered code is searched for in the code list. If the corresponding code is found it is displayed with the defined attributes. If no code list is loaded or the code is not listed then the manual code entry mode is switched to automatically.

Code List Selection

All codes in the code list corresponding to the search criteria entered are found.

```
CODE <Find/Select>
-----
Find :           T*
Code  :           TR ◀▶
Desc. :      Concrete

<EXIT> <MAN> <ATTR> <SET>
```

<ATTR>

Displays all remaining attributes.

<MAN>

Starts manual code entering mode.



With the arrow key scroll through all codes found with the search criteria.

Extending/editing code

Attributes can be overwritten freely.

```
CODE/ ATTR. ENTRY 1/3
-----
Code  :           PLR
ATTR1 :           Pillar
ATTR2 :           CONCRETE

<BACK>                               <SET>
```



Call edit mode and edit attribute.

Exceptions:

With the codelist editor of SurveyOffice a status can be assigned to the attributes.

- Attributes with "fixed status" (see SurveyOffice) are write-protected. They cannot be overwritten or edited.
- For attributes with status "Mandatory" an input of a confirmation is required.
- Attributes with status "Normal" can be edited freely.



Manual code input

Individual code blocks can be entered directly via keypad.

<MAN> starts manual code input and opens an empty code block.

| CODE/ | ATTR. | ENTRY | 1/3 |
|--------|-------|-------|-------|
| Code : | | | ----- |
| Info1: | | | ----- |
| Info2: | | | ----- |
| Info3: | | | ----- |
| Info4: | | | ----- |

 Navigation and numeric/ alphanumeric input possible via cursor keys.

Attributes 5 to 8 can be displayed with <MORE> or  .

 Individually (<MAN>) entered code blocks will not be copied to the codelist.

Error messages

| Messages | Meaning |
|---------------------------|---|
| Attrib. cannot be changed | Attribute with fixed status cannot be changed. |
| No Code-List available | No codelist in memory. Manual input for code and attributes are called automatically. |
| Entry required <OK> | Code missing. Extend input. One or more attributes must be entered or confirmed. |



Leica SurveyOffice
Codelists can be easily
created and uploaded to the
instrument using the supplied
"Leica SurveyOffice" Software.

Possible buttons**<EXIT>**

Quits code function. Returns to previous application or function.

<MAN>

Activates the manual code entry.

<MORE>

Displays more code attributes.

<SET>

Accepts the code entry or selection and temporarily sets the code block in the system .

The code block is saved with the next measurement (REC/ALL).

<REC>

Closes the code entry or code selection and saves the code block.

Quick Code

Using the quick code function, a predefined code can be called directly via the numeric keypad on the instrument. The code is selected by entering a two digit number, the measurement triggered and the measured data and code saved.

A total of 100 codes can be assigned.

Each code can be assigned a unique one or two digit number in the Leica SurveyOffice "Codelist Manager".

If no numbers are allocated to the codes in the "Codelist Manager", the code is selected in accordance with the order in which the codes were entered in the code list (01 -> first code in the code list ... 10 -> tenth code in the code list ... 00 -> hundredth (and last) code in the code list.



A two digit code must always be entered on the instrument's numeric keypad even if only a one digit code was assigned in the Codelist Manager. For example: 4 -> enter 04.



Quick code function is automatically activated, when the cursor is on the <QCODE> button in the last line.

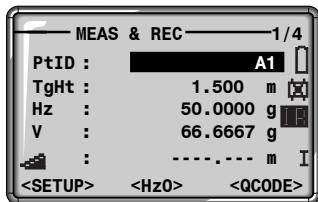

Procedure

1. Position cursor in the "Surveying" or "Point recording" application on the <QCODE> button.
 2. Enter a two digit number on the numeric keypad -> code is selected, the measurement triggered and the measured data and code saved.
- The name of the selected code is displayed after the measurement.



With the "SurveyOffice Codelist Managers" external code lists can be created and transmitted to the instrument via the interface.



The quick code function can only be activated in the "Measuring" and "Surveying" applications (if there is a code list in the memory).

If there are any predefined attributes in the external code lists they must be entered at the instrument by the user. The attribute is automatically displayed.

Menu

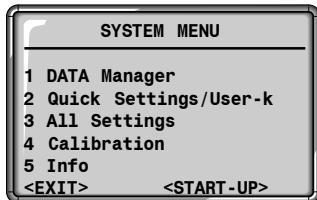
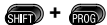

Starting a menu

①..⑤ Direct call up by pressing appropriate key
or

Menu selection.

Execute.

<EXIT>

Quit a menu. Return to "Measurement".

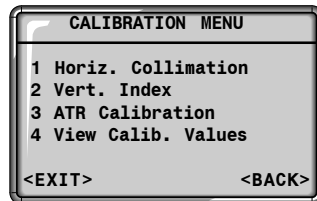
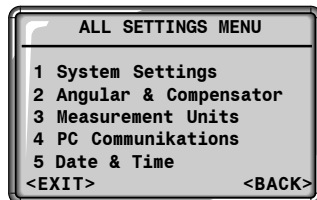
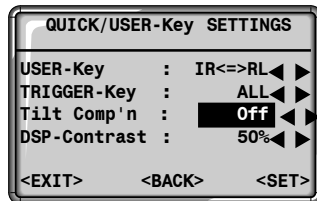
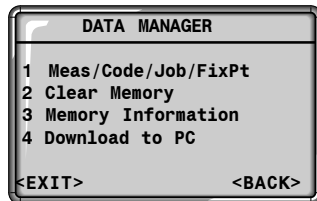

<START-UP>

Sets the screen the instrument starts in when switched on.
E.g. the electronic bubble can be displayed at every start.

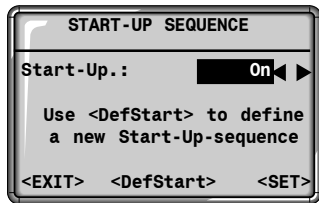
**<EXIT>**

Ends the dialogue. Changed parameters are not stored.

<SET>

Stores current settings.

<DefStart>

Defines the key presses that are executed automatically upon start up.

Procedure:

After confirming the dialogue of notification, the "Meas & Rec" screen is displayed.

A maximum of 16 of the next key presses are stored. The sequence is ended with "Shift ESC ". If the start sequence is activated, the stored key presses are executed automatically when the instrument is switched on.



The automatic start sequence has the same effect as pressing the keys manually. Certain instrument settings cannot be made in this way. "Relative entries" such as automatically setting "IR-FINE" upon switching on the instrument, is not possible.

Data Manager

The Data Manager contains all functions for entering, editing and checking data in the field.

  Open the menu functions.

 Shortcut to the function "DATA MANAGER".

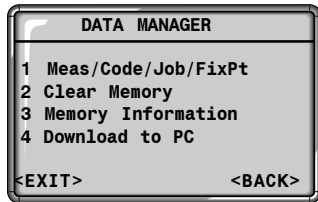

- **View / Edit Data**
Edit, create, view and delete jobs, measurements, fixed points and codelists.
- **Initialize memory**
Delete complete memory, individual jobs or complete data areas (e.g. fixed points, measurements).
- **Data download**
Selected data sets are transferred to the interface without protocol and test procedures.
- **Memory statistics**
Statistical information about job and memory allocation.

View/edit Data

- ① Shortcut to the function "VIEW / EDIT DATA" in the "Data Manager" display.

```

VIEW/ADD/DEL/EDIT DATA
-----
1 Measurements
2 Codes
3 Jobs
4 Fixpoints
<EXIT>                                <BACK>
  
```

EXIT>

Back to Data Manager.

- ①.④ Direct selection of the data type.
- ▲ ▼ Select data type using arrow keys.
- 📄 Opens Data Manager.

Measurements

Measurement data available in the internal memory can be searched and displayed or deleted.

```

VIEW MEASUREMENTS
(Set/Skip Search Filter)
Job :   ▶Projekt_01C ◀▶
PtID:   ▶A*
<EXIT>  <BACK>  <VIEW>
  
```

Selection field for job.

Input of a search criteria for points.



Points can be searched for by two methods:

- Job selection: (e.g. "Project_01C")
- Point selection: Finds all points meeting the conditions mentioned above and also the search criteria for the point search.

```

SURVEY Param 1/3
-----
                2/2 ◀▶
PtID :           A1
TgHt :           1.500 m
Hz :             50.000 g
V :             66.667 g
:               ----- m
<BACK>  <DEL>  <SEARCH>
  
```



If "A*" is entered, all data for which the point ID starts with "A" is found.

  xtended display with coordinates and time information.

Deletes the selected data set from the internal memory.

<SEARCH>

Back to point search.

 Additional data blocks can be recorded in the measuring range irrespective of the program in use.

Corrections:

EDM-Type, EDM-Mode, Prism typ, Prism constant, Atmospheric PPM, Pressure, Ht. Above Sea Level, Temperature, Rel. humid., Refraction Coefficient

Stations:

PtID, E, N, H, hi, Date, Time

Results:

No pts, StDev. Hz, Date, Time, Area, Tie Distance, setout differences, etc.

Measurements:

Pt, Hz, V, SD, Hd, dH, hr, E, N, H, Date, Time

Codes:

Code, Rem., Attr.1-8



You will find detailed information on the storage of data in the section "Saving Data".

Codelist

To each code a description and a maximum of 8 attributes with up to 16 characters can be assigned.

```

CODES in CODELIST 1/3
      < 1/1 >
Find :      Nr*
Code  :      Nr01
Desc  :      Landmark
Info1 :      Nr.123
Info2 :      12.54
<EXIT>  <DEL>  <NEW/EDIT>
  
```

Searching for code:

The codelist can be toggled through in both directions using the arrow keys .

<NEW>

Enter new codelist:
Input of a new code and a descriptive text.

```

ADD NEW CODE to LIST
Code :      Nr01
Desc  :      Landmark
<EXIT> <BACK> <ATTR> <SAVE>
  
```

<ATTR>

Input of attributes (alphanumeric).

<SAVE>

Records inputs; back to code search.

<BACK>

Back to code search; without saving.

Deleting code:

Select relevant code.

Deletes code block.

Extended display for viewing and checking attributes.

Code can be searched directly, either with the code name or wildcard (*).

Job

Jobs are a summary of data of different types, e.g. fixed points, measurements, codes, results, etc.

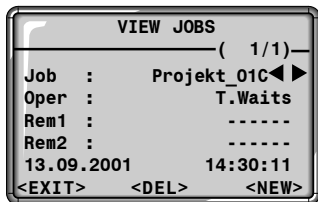

The job definition consists of the input of job name and user. Additionally, the system generates time and date at the time of creation.

Job search:

◀▶ Using the arrow keys the job list can be paged through in both directions.

Deleting job:

◀▶ Select relevant job.

Deletes all data within a job.

Input of a Job:

<NEW>

Defines a new job and job data entry (e.g. job, user).

<SAVE>

Creates and registers the new job.

<BACK>

Back to job search without saving.

Fixed points

Fixed points may be entered with point number, coordinates (E, N) and height.

```

- FIXPOINT - (      5/5)
Job:      Projekt_01C◀▶
Find:          *
PtID:      ABC1◀▶
E   :      31798003.234 m
N   :      15635975.915 m
H   :      8723.001 m
<EXIT>  <DEL>  <NEW/EDIT>
  
```

Valid fixed points contain a minimum of one point number and either the co-ordinates (E, N) or the height (H).

Deletes the selected fixed point.

Enter fixed points:

<NEW / EDIT>

Input of new fixed points and coordinates or editing of existing fixed points by calling the relevant point number.



Within the job selection field the directory for the fixed point is selected.

<EXIT>

Back to fixed point search or display of coordinates.

Fixed point search:

The same conditions are valid here as with point search. You can enter the exact point number or limit the data range by entering a wildcard (e.g. A*).

Delete Memory

Individual jobs or complete data areas of a job are deleted. Deleting all data in memory. Two selection fields enable a specific area to be selected.

- ② Shortcut to the function "CLEAR ONEBOARD MEMORY" in the "Data Manager" display.

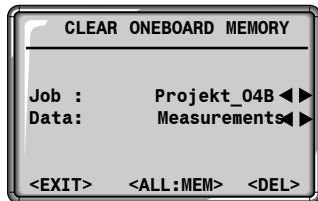

◀▶ Selection of job and data area to be deleted.

Possible data areas:

- measurements
- fixed points
- jobs

DEL>

Starts deleting process within the selected area.

<ALL:MEM>

Deletes all data in memory. All data will be lost !

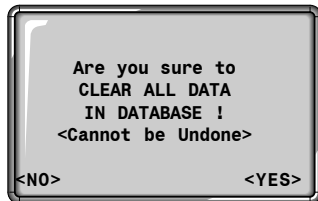

<NO>

Back to selection of area to be deleted. Data is kept.

<YES>

Deletes the selected data area within the selected job.



Deleting the memory cannot be undone. After confirming the message all data is deleted permanently.

Memory Info

It is possible for the user to call-up important information about the status of the internal memory. Additionally, the user can obtain information about the composition of the data in the individual jobs.

- ③ Shortcut to the function "MEMORY INFORMATION" in the "Data Manager" display.

| MEMORY INFORMATION | |
|--------------------|--------|
| Free Jobs: | 5 |
| Job: Projekt_04B | ◀▶ |
| Stations : | 18 |
| FixPoints : | 372 |
| MeasRec's : | 2534 |
| <EXIT> | <BACK> |

<EXIT>

Back to Data Manager.

Stations:

Number of stations used within the selected jobs.

FixPoints:

Number of stored fixed points within the selected jobs.

Meas Recs:

Number of recorded data blocks (measured points, codes, etc.) within the selected jobs.

Free Jobs:

Number of free or not defined jobs.

Data Download

With this special function measured data can be transferred via the serial interface to a receiver (e.g. a Laptop). The success of the transfer is not checked when this type of data transfer is used.

- 4 Shortcut to the function "DATA DOWNLOAD to PC" in the "Data Manager" display.

DOWNLOAD DATA to PC

Job : Project_04B ◀▶

Data : Measurements ◀▶

Form : GSI ◀▶

<EXIT> <BACK> <SEND>



Selection of individual parameters.

<SEND>

Data is sent via interface.

Job

A selection of job from which data should be transferred.

Data

Fixed points or measurements can be sent separately and independently from each other. Selection of data type.

Format

Select output format. The following formats can be selected for output:

1. GSI
2. APA CAD
3. User-defined data formats

User-defined formats must be first loaded using Leica Survey Office (Data Exchange Manager).

Example: "GSI" format

Within the "data" setting "MEASUREMENTS", a data set could have the following appearance:

```
11....+00000D19
21.022+16641826
22.022+09635023
31..00+00006649
58..16+00000344
81..00+00003342
82..00-00005736
83..00+00000091
87..10+00001700
522.16-00000000
```



If the receiver is too slow in processing data the data could be lost. With this type of data transfer the instrument is not informed about the performance of the receiver (no protocol).

Messages and Warnings

Messages

Data SAVED

- Data has been recorded in the internal memory.
- > Display disappears after <1 seconds. Back to last active display.

Data DELETED

- Data has been deleted in the internal memory.
- > Display disappears after <1 seconds. Back to last active display.

Job DELETED

- The content of a complete job has been deleted permanently.
- > Display disappears after <1 seconds. Back to last active display.Warnings

Warnings

No data found in memory!

- No relevant data blocks could be found in the memory.
- > Search for other data or enter relevant data in the Data Manager. Confirm with <OK>. Back to last active display.

Error messages

All memory blocks occupied!!

- Available memory full.
- > Delete a job or data area in the internal memory. Confirm message with <OK>.

Job already exists in database!!

- Job or job name already exists in memory.
- > Change job name. Make sure that the job name is not already available. Confirm message with <OK>.



Invalid Job-Name!!

- Job name is empty or contains a "-".
- > Change job name. Confirm message with <OK>.

Quick Settings

"Quick Settings" are settings frequently used integrated into a common display. All of these settings can also be changed in the configuration.

The parameter or selection fields are controlled via the navigation keys. The current active parameter is indicated by the black bar.

  Calling up menu functions.

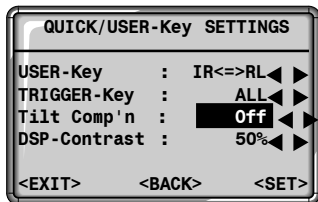

 Shortcut to the function "QUICK SETTINGS".



USER key:

Allocate function from FNC menu.

Trigger key:

Configuration of trigger key located at the side of the instrument. This can be assigned with  or  deactivated.

Tilt Correction:

Switch the compensator on or off.

Contrast:

Set the display contrast in 10% steps.



The display contents, particularly lines, contained in this description can vary in local versions of the software. The function of the display is however identical.

All Settings

This menu enables extensive user-specific settings in order to adapt the instrument to their own requirements.

  Opens the menu functions.

 Shortcut to the function "ALL SETTINGS".

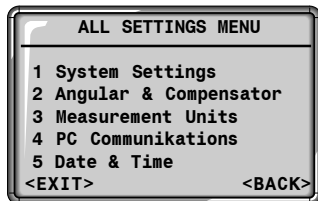

<EXIT>

Leaves "Settings". Back to "Measure".

System Settings

All parameter selection fields are available to the user.

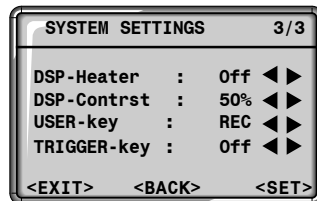
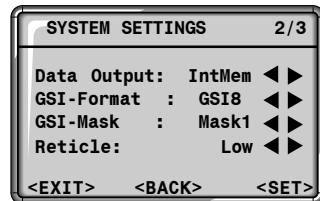
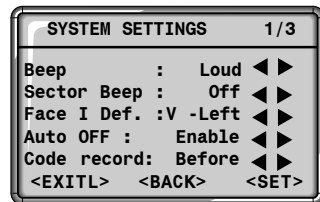

  Displays additional parameters.

  Select a setting.

<EXIT>

Back to "Settings" without setting the changed settings.

<SET>

Sets the changed settings and returns to "Settings".

Beep

The beep sounds after each key press.

Off

Deactivates the beep

Normal

Activates the beep

Loud

Increases volume

Sector Beep

Off

Sector beep off.

Sector beep sounds at right angles (0° , 90° , 180° , 270° , resp. 0, 100, 200, 300gon).

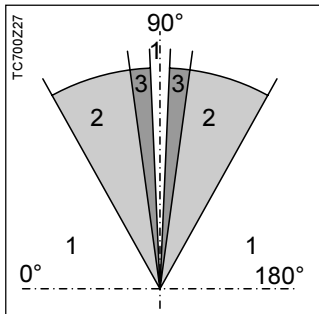

Example Sector Beep:

From 95.0 to 99.5 gon (or from 105.0 to 100.5 gon) "Fast beep" sounds whilst from 99.5 to 99.995 gon (or from 100.5 to 100.005 gon) a "Permanent beep" sounds.

1 No beep

2 Fast beep (interrupted)

3 Permanent beep

Save code

Sets if the codeblock is saved before or after the measurement (see sector "Coding").

Before

Save codeblock before the measurement.

After

Save codeblock after the measurement.

Data Output**RS232**

Data is recorded via the serial interface. For this purpose, a data storage device must be connected.

IntMem

All data is recorded in the internal memory.

AutoOFF**Enable**

The instrument is switched off after 20 minutes without any action (= no key pressed; V and Hz angle deviation $\leq \pm 3'$ / $\pm 600\text{cc}$).

Disable

Function is deactivated and the instrument is permanently operating. The battery will not last for as long.

Sleep

Economy mode. Instrument is recovered by any key stroke.

Display contrast



10%

Setting the display adapting the readability.

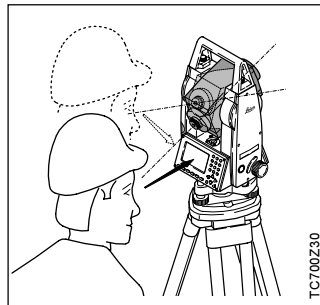
The readability of LCDs is influenced by external conditions (temperature, lighting) and by the reading angle (*see figure*). The display contrast can be adapted step by step until the optimum readability is achieved.



USER-Key

Allocation of a function from FNC menu ( ) to the User key ().

IR<=>RL

Changes the EDM type between IR and RL.

REC

Records a measurement block.

LASERPNT

Switches the visible laser point on or off .

TRACKING

Switches the tracking measurement mode on or off.

OFFSET

Definition of length, cross and/or height offset for target points.

KTR.DIST

Display tie points.

UNZ.PKT

Indirect height measurement.

DLR (Del. Ist Rec)

Delete the last data block registered in the internal memory.

I<->II

Changes telescope face.

ATR

On/ off switch of the automatic target recognition (ATR).

Lfd<->Run

Switches between individual and current point number.

CODE

Code function call up

Trigger Key

Configuration of the trigger key on the side cover.

Off

Trigger key deactivated

ALL

Trigger key with same function as the -key.

DIST

Trigger key with same function as the -key.

Face I Definition

Defines the telescope face I in relation to the position of the V-drive.

V-Left: Telescope face I if V-drive is left hand located.

V-Right: Telescope face I if V-drive is right hand located.

GSI-Format

Select GSI output format.

GSI8:

81..00+12345678

GSI16:

81..00+1234567890123456

GSI-Mask

Select GSI output mask.

Mask 1:

PtID, Hz, V, SD, ppm+mm, hr, hi

Mask 2:

PtID, Hz, V, SD, E, N, H, hr

DSP-Heater

On

Is automatically activated when the display illumination is on and the instrument temperature is $< -5^{\circ}\text{C}$.

Reticle

The reticle illumination is only switched on if the display illumination is on.

Low

Reticle illumination dimmed

Medium

Average brightness

High

strong illumination

Angle Settings

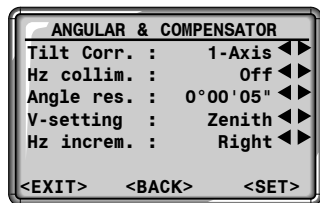

<EXIT>

Quick return to main menu.

Tilt corr

Off

Tilt compensation switched off.

1-Axis

V-angles relate to the plumb line.

2-Axis

V-angles relate to plumb line and the Hz-angles are corrected for the tilt of the standing axis.

If the instrument is used on an unstable base (e.g. shaking platform, ship, etc.) **the compensator should be switched off.**

This avoids the compensator drifting out of its measuring range and interrupting the measuring process by indicating an error.



The compensator setting remains active even after the instrument is switched off.

Hz angle incrementation

Right

Set Hz to "Right angle measurement"
(= clockwise).

Left

Set Hz to "Left angle measurement"
(= counterclockwise).
"Left angle measurements" are only shown in the display. They are recorded as "Right angle measurements" to the internal memory.

V-Reference angle

The "0"- orientation of the vertical circle can be selected to the zenith, the horizontal plane or in %.

Zenit

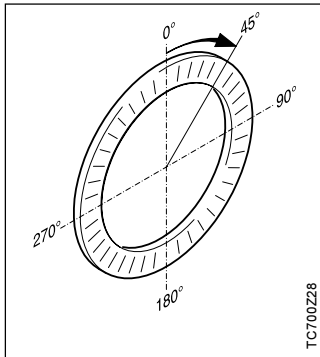

The V-angle increases from 0° - 360° (0 - 400 gon).

Horizontal plane

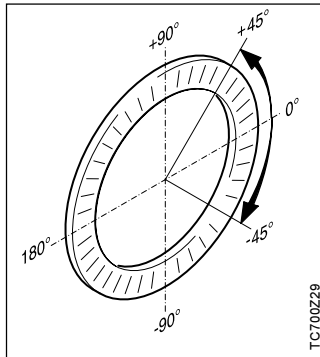

V-angles above the horizontal plane are indicated as positive values and below the horizontal plane as negative values.

Slope%

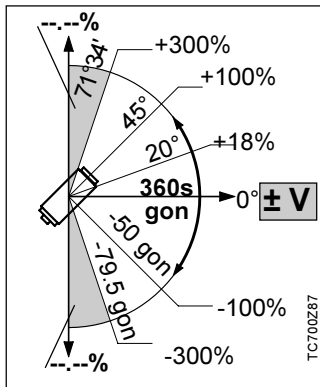

100% correspond to an angle of 45° (50 gon, 800 mil).



The % value increases rapidly. "--.-%" appears on the display above 300%.

Hz collimation

On

Hz-collimation is switched ON.

Off

Hz-collimation is switched OFF.

If option "Hz-collimation ON" is active, each measured Hz-angle is corrected relative to the V-angle.

For normal operation the Hz-collimation remains switched on.



Find more information about the Hz-collimation in section "*Determining instrument errors*".

Resolution

The displayed angle format can be selected in three steps.

- **For 360⁰⁰⁰⁰:**

0° 00' 01" / 0° 00' 05" / 0° 00' 10"

- **For 360°:**

TC(R)702 auto: 0.0001° / 0.0005° / 0.0010°

TC(R)703/705 auto: 0.0005° / 0.0010° / 0.0050°

- **For gon:**

TC(R)702 auto: 0.0001 gon / 0.0005 gon / 0.0010 gon

TC(R)703/705 auto: 0.0005 gon / 0.0010 gon / 0.0050 gon

- **For mil:**

0.01 mil / 0.05 mil / 0.10 mil

Units

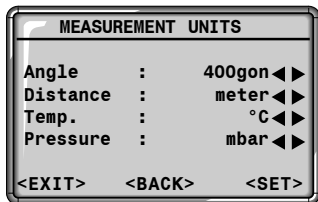

Angle

° ' "

(degree sexagesimal)

Possible angle values:

0° to 359°59'59"

dec. deg

Degree decimal

possible angle values:

0° to 359.999°

gon

Possible angle values:

0 gon to 399.999 gon

mil possible angle values:

0 to 6399.99mil

The setting of the angle units can be changed at any time.

The actual displayed values are converted according to the selected unit.

Distance

meter Meter

ft/in1/8 US-Feet-Inch-1/8 inch

US-ft-2 US-Feet 2 decimales

US-ft-3 US-Feet 3 Decimales

INT-ft Feet International



The INT (internationale) foot / inch-1/8 inch units are not used with the TPS 700 instruments.

If this unit is set via an external interface, then automatically without notice the US foot/ inch-1/8 inch is used.

Temperature

°C Degree Celsius

°F Degree Fahrenheit

Pressure

mbar Millibar

hPa Hecto Pascal

mmHg Millimeter mercury column

inHg Inch mercury column

Communication

| COMMUNICATION SETTINGS | | |
|------------------------|--------|-------|
| Baudrate : | 19200 | ◀▶ |
| Databits : | 8 | ◀▶ |
| Parity : | None | ◀▶ |
| Endmark : | CR/LF | ◀▶ |
| Stopbits : | 1 | |
| <EXIT> | <BACK> | <SET> |

For data transfer between PC and instrument the communication parameters of the serial interface RS232 must be set.

Leica Standard setting:

19200 Baud, 8 Databit, No Parity,
1 Stopbit, CR/LF

Baudrate

Data transfer speed 2400, 4800, 9600, 19200 [bits/second]

Databits

- 7 Data transfer is realized with 7 databits. Is set automatically if parity is "Even" or "Odd".
- 8 Data transfer is realized with 8 databits. Is set automatically if parity is "None".

Parity

| | |
|------|-------------------------------------|
| Even | Even parity |
| Odd | Odd parity |
| None | No parity (if data bit is set to 8) |

Endmark

| | |
|-------|----------------------------|
| CR/LF | Carriage return; line feed |
| CR/LF | Carriage return |

Stopbits

Firm setting 1.

Interface plug connections:

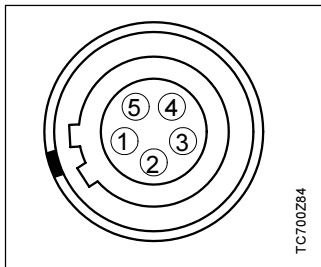

- 1 External battery
 - 2 Not connected / inactive
 - 3 GND
 - 4 Data reception (TH_RXD)
 - 5 Data transfer (TH_TXD)
- TH ... Theodolite

Date and Time

For displaying and setting of date and time.

Time:

hh:mm:ss
(hours, minutes, seconds)

Date:

dd:mm:yyyy
(day, month, year)



Selects an input field.



Activates edit mode.

The time/date is immediately set for the complete system after input.

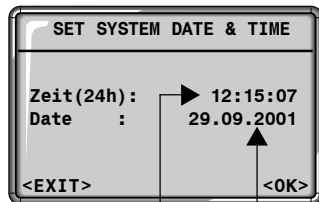

Adjustable Date

Adjustable Time

Determining Instrument Errors

The calibration contains the determination of the following instrument errors:

- Hz-collimation
- V-index (simultaneously electronic level)

 Opens the menu functions.

 Shortcut to the function "CALIBRATION".

To determine instrument error measurements must be made in both telescope faces. Either telescope face may be the starting point.

The user is guided clearly through the procedure. As a result, a wrong determination of instrument error is eliminated.



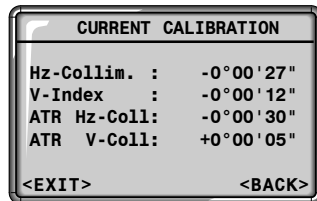
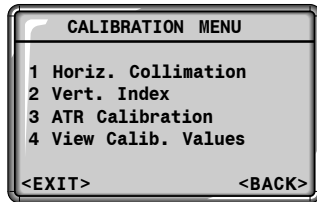

With motorized instruments a switch to the next telescope face takes place automatically after a measurement. The surveyor only has to make the fine adjustments.



Buttons:

<MEAS>

Measurements are triggered exclusively by pressing this button. Buttons  or  are not active during calibration.

EXIT>

Back to calibration menu without saving.

<PREV>

Back to last active display.

The instruments are adjusted in the factory prior to shipping.

Instrument errors can change with time and temperature.



These errors should be determined before the instrument is used for the first time, before precision surveys, after long periods of transport, before and after long periods of work, and if the temperature changes by more than 10°C (18°F).



Before determining the instrument errors, level-up the instrument using the electronic bubble. The instrument should be secure and firm, and should be protected from direct sunlight in order to avoid thermal warming on one side only.

Line-Of-Sight Error (Hz-Collimation) V-Index (Vertical Index Error)

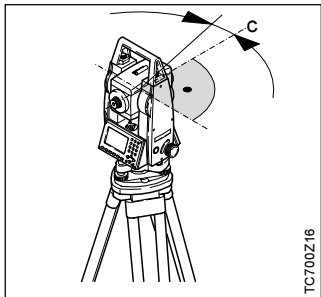

The line-of-sight error or collimation error (C) is the deviation from the perpendicular between tilting axis and line of sight.

The effect of the line-of-sight error to the Hz-angle increases with the vertical angle. For horizontal aimings the error of Hz-angle equals line-of-sight error.

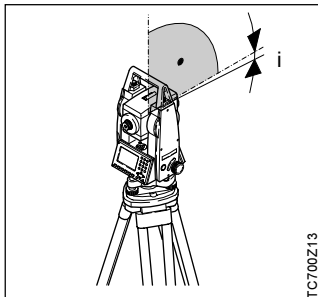

The vertical circle should read exactly 90° (100 gon) when the line of sight is horizontal. Any deviation from this figure is termed vertical index error (i).

By determining the vertical index error (i) the electronic level is adjusted automatically.

Determining The Line-Of-Sight Error (c)

1. Level up instrument exactly using the electronic level.
2. Target a highly visible point at about 100 m distance. The target may not deviate more than $\pm 4^{\circ}30'$ (5 gon) from the horizontal line.

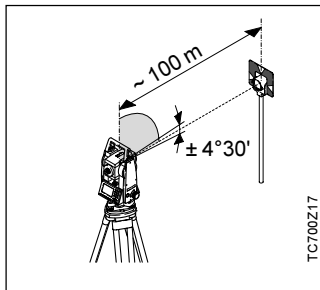

For checking the horizontal aiming Hz and V are displayed.

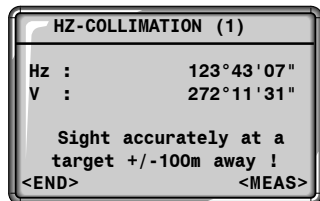

3. <MEAS> Trigger measurement.
4. Change telescope face and aim on point again.

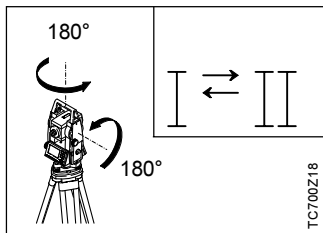

5. Trigger measurement again.

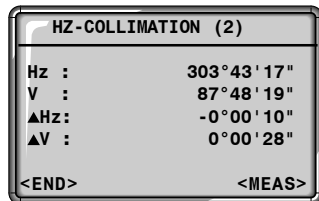

6. Indication of previous and recomputed line-of-sight-error.

| HZ-COLLIMATION (c) | |
|--------------------|-----------|
| c(old): | -0°00'27" |
| c(new): | -0°00'25" |

The new value can be either accepted with <SET> or rejected with <EXIT>.

Determining V-Index

1. Level up instrument exactly using the electronic level.
2. Target a highly visible point at about 100 m distance. The target may not deviate more than $\pm 4^{\circ}30'$ (5 gon) from the horizontal line.

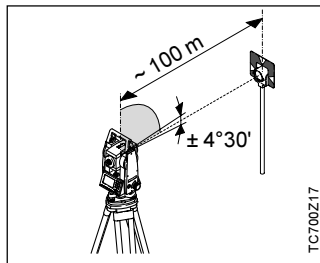

By determining the vertical index error the electronic level is adjusted automatically.

For checking the horizontal aiming Hz and V are displayed.

3. Trigger measurement.

| V-INDEX (1) | |
|---|------------|
| Hz : | 123°43'07" |
| V : | 272°11'31" |
| Sight accurately at a target +/-100m away ! | |
| <END> | <MEAS> |

4. Change telescope position and aim on point again.

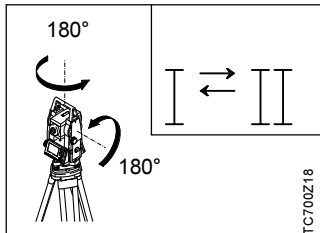

6. Indication of previous and recomputed V-index.

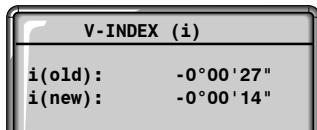

The new value can be either accepted with <SET> or rejected with <EXIT>.

5. Trigger measurement again.

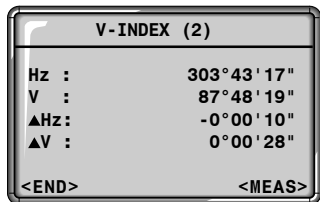

The determined instrument error is displayed as an error. In correcting the measurement the error is added with reversed sign to the measurement.

ATR collimation

(Available for TC and TCRauto versions only)

The ATR collimation error is the combined horizontal and vertical angular divergence of the line of sight from the axis of the CCD camera. The collimation procedure includes, optionally, the determination of the line-of-sight error and the vertical-index error. The correction for the ATR collimation errors is always applied regardless of the "ON/OFF" status of the Hz-correction setting. (see section "Angle settings").

To define the ATR collimation error, a prism must be accurately targeted at a distance of about 100 m. The target must lie within $\pm 9^\circ$ (± 10 gon) of the horizontal plane. The procedure is analogous to that of determining the V-index error.

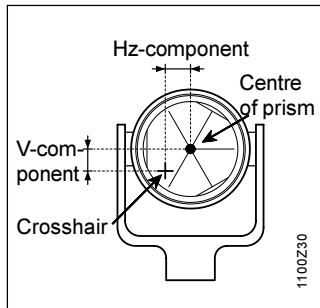

Aim the reticle exactly at the middle of the prism.

<MEAS>

Starts the calibration.

The two-axis compensator is turned off automatically when determining the ATR collimation error.

After the first measurement is completed there is an automatic switch to the second telescope face.

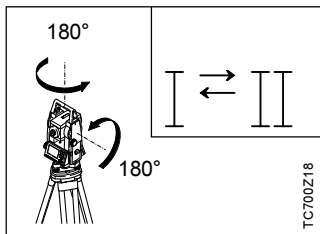

Aim the reticle exactly at the prism in the second face and trigger the measurement with <Meas>.

If the differences of the horizontal direction and vertical angle is outside of $\pm 27'$ (± 0.5 gon), an error message is displayed. Otherwise the following is displayed.

| ATR-COLLIMATION 1 | |
|---|------------|
| Hz : | 0.0000 g |
| V : | 100.0000 g |
| Sight accurately at a prism +/-100m away ! | |
| <END> | <MEAS> |

<END>
Quit the menu.

| ATR-COLLIMATION 2 | |
|-------------------|------------|
| Hz : | 200.0000 g |
| V : | 300.0000 g |
| ΔHz : | + 0.0000 g |
| ΔV : | + 0.0000 g |
| <END> | <MEAS> |

| ATR-COLLIMATION <m.F.> | |
|------------------------|-----------------|
| No.of Meas: | 1 |
| m.F.Hz Col : | +0.0018 g |
| m.F.V Col : | +0.0036 g |
| More Measurements | |
| <END> | <RESULT> <MORE> |

<MORE>

For repeated measurements.
Calibration can be repeated until
the desired degree of accuracy is
reached.



Three measurement are
recommended.

<RESULT>

Calculates the ATR accuracy
from the current measured
values. It is only possible with at
least 2 measurements in 2 faces
were made.

| ATR-COLLIMATION RESULT | |
|------------------------|-------------|
| Hz | : -0.0738 g |
| Hz (old) | : +0.0000 g |
| V | : -0.0738 g |
| V (old) | : 0.0000 g |
| <END> | |
| <OK> | |

<OK>

Set the new calibrated values.

<EXIT>

Function is interrupted and the
calibration values are retained.

Possible Messages when Determining Instrument Errors

| Messages | Meaning | Measures taken |
|--|--|---|
| V-angle cannot be used for calculations (check angle or face) | The tolerance of aiming was not kept or telescope face was not changed. | The target point must be approx. horizontal ($\pm 4^{\circ}30'$). Message must be confirmed. |
| Beyond adjustment tolerances, old values are retained. | Calculated values outside of tolerance. Old values are retained. | Repeat measurements. Message must be confirmed. |
| Hz-angle outside of tolerance. | Hz-angle in second face deviates more than $4^{\circ}30'$ from target point. | Aim at the target with an accuracy of at least $4^{\circ}30'$. Message must be confirmed. |
| Repeat measurement error! | Measurement error occurred (e.g. instable setup or time interval between telescope face I and II is too long). | Repeat the process. Message must be confirmed. |

| Messages | Meaning | Measures to take |
|--|--|---|
| Vertical angle not suited for adjustment. | The vertical angle may not deviate by more than +/- 10g from the horizontal during calibration. | Adjust reflector height to enable approx. horizontal sighting. |
| No prism were found or the weather is bad. | This message may be displayed in bad weather (e.g. in fog) or if the prism is too far away. | The prism has to be aimed at more exactly and the measurement repeated. The ATR may be switched off, too. |
| Several prism were found. | Several prism are in the field of view of the telescope during ATR search. | The target prism must be aimed at more exactly and the measurement repeated. |
| Exact positioning is not possible. | A runtime error while positioning has occurred. Heat flickering or an instable prism location are possible causes. | Repeat the measurements. |
| Instrument is turning. | The instrument changes face and positions itself automatically on the reflector. | During this interval do not manually move the alidade or the drives. |

System-Info

Useful information which can be called via menu. These are only indications of actual setting and cannot be changed here. All changes to settings must be carried out in menu "SETTINGS".

  Opens the menu functions.

 Shortcut to the function "INFO".

| SYSTEM INFO | | 1/2 |
|--------------|--------|-----------|
| 14.09.2001 | | 15:11:42 |
| Free Jobs : | | 12 |
| USER-Key : | | REC |
| TRIGGER-Key: | | ALL |
| Battery : | | 20% |
| <EXIT> | <BACK> | <SW-VERS> |

| SYSTEM INFO | | 2/2 |
|---------------|--------|-----------|
| Instr. Temp.: | | 25°C |
| DSP Heater : | | Off |
| Hz-Coll. : | | Off |
| Tilt Corr. : | | Off |
| <EXIT> | <BACK> | <SW-VERS> |

<SW-Version>

Software versions overview.

| | |
|------------------|--------------|
| TCR702 | 641238 |
| RL-EDM : | Normal Range |
| Operat.-System : | 4.00 |
| Application-SW : | 89.17 |
| Layout : | en2.00 |
| EDM: 1.10 | ATR: 0.00 |
| <EXIT> | <BACK> |

Information on settings not described here can be found in section (*section system settings*)

Free Jobs

Number of free jobs is displayed. If no jobs are in the memory under "Measure and Record" the system creates a "Default" job automatically. All data is stored into this Default job which can be freely renamed.

Battery

Remaining battery power (e.g. 40%).

Instr.Temp.

Measured instrument temperature.

Calibration Values

Indication of last determined and stored calibration values (Hz-collimation, V-index).



Saving Data

The following categories of data are stored in the internal memory:

- Measured data
- Fixed points
- Jobs

The measured data are subdivided into different objects (measurements, target points, stations, results, residuals, correction parameters, codes). Depending on the application, one or more of these objects are saved, the contents (attributes) of the objects are described in the following. The time and date are also saved at the same time with each object, as well as the name of the application in which the objects were saved.

Comment on the "Measurement" object:

E, N, H,  and  are **calculated** from the measurements (applies to all applications).

Adjustment values

Displays the last made and saved adjustment values (Hz-colimation, V-index)

Start-Up Programs

Job

| | | |
|------|---|---------------|
| Job | = | Job name |
| Oper | = | Observer name |
| Rem1 | = | Comment 1 |
| Rem2 | = | Comment 2 |
| Date | = | Date |
| Time | = | Time |

Station

| | | |
|-----|---|-----------------------------------|
| Stn | = | Station number |
| E0 | = | Station co-ordinate (Easting) |
| N0 | = | Station co-ordinate (Northing) |
| H0 | = | Station height |
| hi | = | Instrument height |

Orientation

Target Point (1):

| | | |
|---------|---|----------|
| PtID(1) | = | Point ID |
| E(1) | = | Easting |
| N(1) | = | Nothing |
| H(1) | = | Height |

Measurement (1):

| | | |
|---|---|----------------------------|
| PtID(1) | = | Point ID |
| Hz(1) | = | Horizontal angle |
| V(1) | = | Vertical angle |
|  (1) | = | Measured slope distance |
| hr(1) | = | Reflector height |

Target Point (n):

| | | |
|---------|---|----------|
| PtID(n) | = | Point ID |
| E(n) | = | Easting |
| N(n) | = | Northing |
| H(n) | = | Height |

Measurement (n):

| | | |
|--|---|----------------------------|
| PtNr(n) | = | Point ID |
| Hz(n) | = | Horizontal angle |
| V(n) | = | Vertical angle |
|  (n) | = | Measured slope distance |
| hr(n) | = | Reflector height |



Results:

| | | |
|---------|---|--|
| PtID(1) | = | Point ID of the first target point |
| Brg | = | Calculated azimuth between the station co-ordinates and the first target point (based on the telescope face in which orientation was performed) |

Applications

- NoPts = Number of target points used
- HzCor = Hz circle correction
- St Dev = Standard deviation of the Hz circle correction
- Face = Telescope face in which orientation was performed

Residuals:

- ▲Hz = Residual for the horizontal angle
- ▲  = Residual for the horizontal distance
-  = Height residual

Measuring Application

Measurement:

- PtNr = Point ID
- Hz = Horizontal angle
- V = Vertical angle
-  = Measured slope distance
- hr = Reflector height

Survey Application

Measurement:

- PtNr = Point ID
- Hz = Horizontal angle
- V = Vertical angle
-  = Measured slope distance
- hr = Reflector height

Setting-Out Application**Target Point:**

| | | |
|------|---|----------|
| PtID | = | Point ID |
| E | = | Easting |
| N | = | Northing |
| H | = | Height |

Measurement:

| | | |
|--|---|-------------------------|
| PtNr | = | Point ID |
| Hz | = | Horizontal angle |
| V | = | Vertical angle |
|  | = | Measured slope distance |
| hr | = | Reflector height |

Results:

| | | |
|---|---|---|
| ▲E | = | Easting setting-out difference between target and measured point |
| ▲N | = | Northing setting-out difference between target and measured point |
| ▲  | = | Height setting-out difference between target and measured point |



Tie Distance Application**Measurement (1):**

| | | |
|--|---|-------------------------|
| PtNr(1) | = | Point ID |
| Hz(1) | = | Horizontal angle |
| V(1) | = | Vertical angle |
|  (1) | = | Measured slope distance |
| hr(1) | = | Reflector height |

Measurement (n):

| | | |
|--|---|-------------------------|
| PtNr(n) | = | Point ID |
| Hz(n) | = | Horizontal angle |
| V(n) | = | Vertical angle |
|  (n) | = | Measured slope distance |
| hr(n) | = | Reflector height |

Measurement (n-1) - (n):

| | | |
|--|---|---------------------|
|  | = | Slope distance |
|  | = | Horizontal distance |
|  | = | Height difference |
| Azi | = | Azimuth |

Area Application**Measurement (1):**

- PtNr(1) = Point ID
Hz(1) = Horizontal angle
V(1) = Vertical angle
 (1) = Measured slope distance
hr(1) = Reflector height

Measurement (n):

- PtNr(n) = Point ID
Hz(n) = Horizontal angle
V(n) = Vertical angle
 (n) = Measured slope distance
hr(n) = Reflector height

Results:

- NoPts = Number of points
Area = Area
Perim. = Perimeter of area

Free Station Application**Target Point (1):**

- PtID(1) = Point ID
E(1) = Easting
N(1) = Northing
H(1) = Height

Measurement (1):

- PtNr(1) = Point ID
Hz(1) = Horizontal angle
V(1) = Vertical angle
 (1) = Measured slope distance
hr(1) = Reflector height

Target Point (n):

- PtID(n) = Point ID
E(n) = Easting
N(n) = Northing
H(n) = Height

Measurement (n):

- PtNr(n) = Point ID
Hz(n) = Horizontal angle
V(n) = Vertical angle
 (n) = Measured slope distance
hr(n) = Reflector height

Station results:

- Stn = Station number
E = Station co-ordinate (Easting)
N = Station co-ordinate (Northing)
H = Station height
hi = Instrument height

Standard deviations:

StDv(E) = Standard deviation of the station co-ordinates (Easting)

StDv(N) = Standard deviation of the station co-ordinates (Northing)

StDv(H) = Standard deviation of the station height

StDv(P) = Average point position error

$$= \sqrt{mF(E)^2 + mF(N)^2}$$

VResiduals:

▲Hz = Residual on the horizontal angle

▲  = Residual on the horizontal distance

▲  = Height residual

Orientation point (1):

PtID(1) = Point ID

E(1) = Easting

N(1) = Northing

H(1) = Height

Orientation measurement (1):

PtID(1) = Point ID

Hz(1) = Measured horizontal angle + orientation unknowns

V(1) = Vertical angle

 (1) = Measured slope distance

hr(1) = Reflector height

Orientation results:

- PtID(1) = Point ID of the first target point
- Brg = Calculated azimuth between the station co-ordinates and the first target point (based on the telescope face in which orientation was performed)
- NoPts = Number of target points used
- HzCor = Hz circle correction
- StDev = Standard deviation of the Hz circle correction
- Face = Telescope face in which orientation was performed.

Reference Line Application

• Reference line

Measurement (1):

- PtID = Point ID
- Hz = Horizontal angle
- V = Vertical angle
-  = Measured slope distance
- hr = Reflector height

Target Point (1):

- PtID = Point ID
- E = Easting
- N = Northing
- H = Height

Measurement (2):

- PtID = Point ID
- Hz = Horizontal angle
- V = Vertical angle
-  = Measured slope distance
- hr = Reflector height

Target Point (2):

- PtID = Point ID
- E = Easting
- N = Northing
- H = Height

Transformation Parameters:

- Line = Longitudinal offset
- Offs = Parallel offset
- Hoff = Height offset
- Rot = Rotation

• Reference Line Measurement:

- PtID = Point ID
- Hz = Horizontal angle
- V = Vertical angle
-  = Slope distance
- hr = Reflector height

Results:

- ▲Line = Longitudinal offset
with respect to
reference point
- ▲Offs = Transverse offset
with respect to
reference point
- ▲  = Height offset with
respect to reference
point

**Orthogonal setting out
Orthogonal setting out
elements:**

- PtID = Point ID
Line = Longitudinal value
Offs = Transverse value
Ht = Height value

• Measurement:

- PtID = Point ID
Hz = Horizontal angle
V = Vertical angle
 = Slope distance
hr = Reflector height

Results:

- ▲Line = Longitudinal
difference required -
actual
- ▲Offs = Transverse
difference required -
actual
- ▲  = Height difference
required - actual

Sets of Angles Application**Measurement (1):**

- PtID(1) = Point ID
Hz(1) = Hz-angle
V(1) = V-angle
 (1) = Measured slope
distance
TgHt(1) = Reflector height

Measurement (n):

- PtID(n) = Point ID
Hz(n) = Hz-angle
V(n) = V-angle
 (n) = Measured slope
distance
TgHt(n) = Reflector height

Sets Hz Results

- Active Sets = Number of Sets of Angles used for the calculation
- Active Pts = Number of targets used for the calculation
- σ SingleDir = Standard deviation of the direction of a single Set of Angles
- σ Avg. Hz = Standard deviation of the direction calculated from all Sets of Angles

Sets Hz Mean

- PtID = Point ID
- Pt# = Current point counter
- Avg.Hz = Average (Hz) of all Sets of Angles
- TgHt = Reflector height
- EDM Mode = Applied EDM mode, measurement program
- mm = Prism constant [mm]
- Prism Type = Prism type
- ATR on/off = ATR (on/off)

Sets Hz Residuals

- PtID = Point ID
- Set# = Current Set of Angles counter
- Pt# = Current point counter
- Residual = Difference between single and calculated Sets of Angles
- Hz redu. = Set of Angles (Hz) reduced to the current point

Sets V Results

- Active Sets = Number of Sets of Angles used for the calculation
- Active Pts = Number of targets used for the calculation
- σ SingleDir = Standard deviation of a single V-angle
- σ Avg. V = Standard deviation of the V- angle calculated from all Sets of Angles

Sets V Mean

| | |
|------------|---|
| PtID | = Point ID |
| Pt# | = Current point counter |
| Avg. V | = Average (V) of all Sets of Angles |
| TgHt | = Reflector height |
| EDM Mode | = Applied EDM mode, measurement program |
| mm | = Prism constant [mm] |
| Prism Type | = Prism type |
| ATR on/off | = ATR (on/off) |

Sets V Residuals

| | |
|----------|---|
| PtID | = Point ID |
| Set# | = Current Set of Angles counter |
| Pt# | = Current point counter |
| Residual | = Difference between single and calculated Sets of Angles |
| V redu. | = Average of the Sets of Angles (V) to the current point |

Sets Dist Results

| | |
|--------------------|---|
| Active Sets | = Number of Sets of Angles used for the calculation |
| Active Pts | = Number of targets used for the calculation |
| σ SinglDist | = Standard deviation of a single distance |
| σ Avg. Dist | = Standard deviation of the distance calculated from all Sets of Angles |

Sets Dist Mean

| | |
|------------|--|
| PtID | = Point ID |
| Pt# | = Current point counter |
| Avg. Dist | = Average (distance) of all Sets of Angles |
| TgHt | = Reflector height |
| EDM Mode | = Applied EDM mode, measurement program |
| mm | = Prism constant [mm] |
| Prism Type | = Prism type |
| ATR on/off | = ATR (on/off) |

Sets Dist Residuals

| | |
|----------|--|
| PtID | = Point ID |
| Set# | = Current Set of Angles counter |
| Pt# | = Current point counter |
| Residual | = Difference (Dist) between single and calculated distance |
| Dist.red | = Average of Sets of Angles (Dist) to the current point |

Functions

Determination of the Height of Remote Points

Measurement (1):

| | |
|---|------------------------------|
| PtID(1) | = Point ID |
| Hz(1) | = Horizontal angle |
| V(1) | = Vertical angle |
|  (1) | = Measured slope distance |
| hr(1) | = Reflector height |

Measurement (n):

| | |
|---|------------------------------|
| PtID(n) | = Point ID |
| Hz(n) | = Horizontal angle |
| V(n) | = Vertical angle |
|  (n) | = Measured slope distance |
| hr (n) | = Reflector height |

Results (n-1) - (n):

| | |
|---|---------------------|
|  | = Height difference |
|---|---------------------|

Target Offset

| | |
|----------|-----------------|
| L_Offset | = Length offset |
| T_Offset | = Cross offset |
| H_Offset | = Height offset |

Correction Parameters

A correction block is stored every time when:

- a new job is stored or
- one or more parameters are changed in the EDM settings in the instrument (see list below).

EDM

EDM type
EDM mode
Prism type
Prism constants

Atmospheric Corrections

| | | |
|--------------|---|-------------------------------|
| Pressure | = | Air pressure |
| Temperature | = | Temperature |
| Rel. humid. | = | Relative atmospheric humidity |
| Refr. Coeff. | = | Coefficient of refraction |
| Ht. a. MSL | = | Height above see level |
| Atmos ppm | = | Atmospheric PPM |

Coding

OSW-Coding

| | | |
|-------|---|------------------|
| Code | = | Name of code |
| Desc | = | Comment |
| Attr1 | = | Attribute name 1 |
| Attr2 | = | Attribute name 2 |
| Attr3 | = | Attribute name 3 |
| Attr4 | = | Attribute name 4 |
| Attr5 | = | Attribute name 5 |
| Attr6 | = | Attribute name 6 |
| Attr7 | = | Attribute name 7 |
| Attr8 | = | Attribute name 8 |

Fixed Points (Coordinates) RS232

GSI-Coding

| | |
|-------|-----------------|
| Code | = Name of code |
| Desc | = Comment |
| Info1 | = Information 1 |
| Info2 | = Information 2 |
| Info3 | = Information 3 |
| Info4 | = Information 4 |
| Info5 | = Information 5 |
| Info6 | = Information 6 |
| Info7 | = Information 7 |
| Info8 | = Information 8 |

| | |
|------|------------|
| PtID | = Point ID |
| E | = Easting |
| N | = Northing |
| H | = Height |

Measurements (PtID, Hz, V, , hr) are output over the RS232 serial interface if data output over RS232 is set.



No results or other calculated data (e.g. ) is output over the RS232 serial interface.

The type of data output (internal memory or RS232) is set in the menu (see MENU / SYSTEM INFO).

Index

| | |
|------------------------------|----|
| 360° Mini prism GRZ101 | 15 |
| 360° Prism GRZ121 | 14 |
| 360° Prism GRZ4 | 14 |

A

| | |
|----------------------------------|-----|
| Air pressure | 18 |
| Angle | 141 |
| Angle Settings | 137 |
| Applications | 159 |
| Area Computation | 100 |
| Atmos_ppm | 18 |
| ATR collimation | 150 |
| ATR-Mode | 22 |
| ATR-search | 23 |
| Automatic Reflector Search | 23 |
| AutoOFF | 134 |

B

| | |
|------------------------|--------|
| Base line | 71 |
| Base point | 26, 72 |
| Battery | 156 |
| Baudrate | 142 |
| Button functions | 46 |

C

| | |
|-----------------------------|----------|
| CALIBRATION | 144 |
| Calibration Values | 156 |
| Cartesian Setout | 63 |
| Check Tie | 32 |
| Code list | 109, 122 |
| Codeblock Searches | 109 |
| Coding | 108, 168 |
| Communication | 142 |
| Computation Procedure | 53 |
| Computed Orientation | 44 |
| Contrast | 131 |
| Correction Parameters | 168 |

D

| | |
|---|-----|
| Data | 127 |
| DATA DOWNLOAD | 119 |
| Data Download | 127 |
| Data Manager | 119 |
| Data Output | 134 |
| Databits | 142 |
| Date | 143 |
| Date and Time | 143 |
| Delete complete memory | 119 |
| Delete Last Record | 31 |
| Delete Memory | 125 |
| Deleting code | 122 |
| Deleting job | 123 |
| Determining Instrument Errors | 144 |
| Determining The Line-Of-Sight Error (c) | 147 |
| Determining V-Index | 148 |
| Dist Mode | 11 |
| Distance | 141 |

E

| | |
|------------------------------|-----|
| EDM Settings | 11 |
| EDM signal | 19 |
| Endmark | 142 |
| Enter fixed points | 124 |
| Extending/editing code | 111 |

F

| | |
|----------------------------------|----------|
| Face I Definition | 136 |
| Fixed point search | 124 |
| Fixed points | 124 |
| Fixed Points (Coordinates) | 169 |
| Fixpoint | 8 |
| Fixpoints | 126 |
| FNC menu | 24 |
| Format | 127 |
| Free Jobs | 126, 156 |
| Free Station | 50 |
| Functions | 167 |

G

| | |
|-----------------------|-----|
| GSI-format | 128 |
| GSI-Mask | 136 |
| Guide Light EGL | 16 |

H

| | |
|--|-----|
| Height above sea level | 18 |
| Height Determination of Remote Points .. | 26 |
| HEIGHT TRANSFER | 38 |
| Horizon | 138 |
| Horizontal plane | 138 |
| Ht. a. MSL | 18 |
| Hz collimation | 139 |
| Hz-Collimation | 146 |

I

| | |
|-------------------------|-----|
| Initialize memory | 119 |
| Input of a Job | 123 |

J

| | |
|------------------|----------|
| Job | 123, 127 |
| Job search | 123 |

K

| | |
|-------------------|----|
| Known Point | 38 |
|-------------------|----|

L

| | |
|---------------------------|-----|
| Laserpoint | 29 |
| LINE&OFFSET | 77 |
| Line-Of-Sight Error | 146 |

M

| | |
|--|-------|
| Manual code input | 112 |
| Manual Input of Setting Out Values | 64 |
| Meas Recs | 126 |
| Measurement | 8, 10 |
| Measurements | 120 |
| Miniprism GMP101/102 | 13 |
| Miniprism GMP111/111-0 | 13 |

O

| | |
|-------------------------|--------|
| Orientation | 41 |
| Orthogonal Setout | 63, 76 |

P

| | |
|------------------------|---------|
| Parity | 142 |
| Plug connections | 143 |
| Point Search | 8 |
| Polar Setout | 63 |
| Pressure | 18, 141 |
| Prism constant | 16 |
| Prism type | 13 |

Q

| | |
|----------------------|---------|
| Quick Code | 48, 115 |
| Quick Settings | 131 |

R

| | |
|------------------------------|--------|
| Radial Methods | 69 |
| REC (Storing) | 33 |
| Reference Line | 71, 73 |
| Reference point | 73 |
| Reflective targets | 14 |
| Refraction Coefficient | 18 |
| Refraction correction | 19 |
| Relative Humidity | 18 |
| Remote Point | 26 |
| Residuals | 44, 58 |
| Resolution | 140 |
| Reticle | 137 |
| RL-Prism | 12 |
| RL-Short | 12 |
| RL-Track | 12 |
| RS232 | 169 |

S

| | |
|--|-----|
| Saving Data | 157 |
| Searching for code | 122 |
| Set Hz0 | 41 |
| Setting Out | 61 |
| Setting Out Coordinates from Memory | 61 |
| Setting Station | 38 |
| Setting-Out via PC | 104 |
| Settings | 132 |
| Slope% | 139 |
| Start-Up Programs | 158 |
| Starting a menu | 117 |
| Stations | 126 |
| Stopbits | 142 |
| Surveying | 48 |
| System Settings | 132 |

T

| | |
|---------------------------------|----------|
| Target Offset | 27 |
| Temperature | 18, 141 |
| Tilt correction | 131 |
| Time | 143 |
| Tracking | 29 |
| Transformation Parameters | 163 |
| Trigger Key | 131, 136 |

U

| | |
|----------------|----------|
| Unit | 141 |
| USER-Key | 131, 135 |

V

| | |
|----------------------------|-----|
| V-Index | 146 |
| V-Reference angle | 138 |
| Vertical Index Error | 146 |
| VIEW / EDIT DATA | 119 |

W

| | |
|-----------------------|----|
| Wildcard Search | 10 |
|-----------------------|----|

Z

| | |
|-------------|-----|
| Zenit | 138 |
|-------------|-----|

Total Quality Management: Our commitment to total customer satisfaction



Leica Geosystems AG, Heerbrugg, Switzerland, has been certified as being equipped with a quality system which meets the International Standards of Quality Management and Quality Systems (ISO standard 9001) and Environmental Management Systems (ISO standard 14001).

Ask your local Leica Geosystems agent for more information about our TQM program

Leica Geosystems AG

Heinrich-Wild-Strasse
CH-9435 Heerbrugg
Switzerland
Phone +41 71 727 31 31

www.leica-geosystems.com

- when it has to be **right**

Leica
Geosystems